

ROTATING RIGHT

MODEL 5S-2 SINGLE ACTING SIMPLEX PUMP



5S-2

A 5 horsepower 2.188" stroke horizontal simplex single acting plunger pump. Available in four different fluid end materials at pump speeds up to 350 RPM. Multiple liner sizes allow pressures and volumes to handle circulation requirements in deep drilling

Power End Features:

- Cast iron power frame
- Alloy steel crosshead pins
- Heavy-duty roller crankshaft bearings
- Precision type, aluminum alloy crankpin bearings
- Cast iron connecting rods
- Ductile Iron crankshaft with ground journals & polished throws
- Bronze bearing crosshead pin bushings
- Cast iron crossheads with upper/lower oil grooves
- One piece plungers
- Flooded sump, splash distribution lubrication
- Rated rod load is 2030 lbs

Fluid End Features:

- Bolted Covers forged Liquid Ends
- Threaded type glands & integral stuffing boxes
- Bronze stuffing box bushings and packing followers
- Optional flanged connections available
- Abrasion Resistant Valves
- Plungers - Solid Ceramic, or Tungsten Coated
- Spring loaded Plunger Packing

5S-2 Simplex Plunger Pump

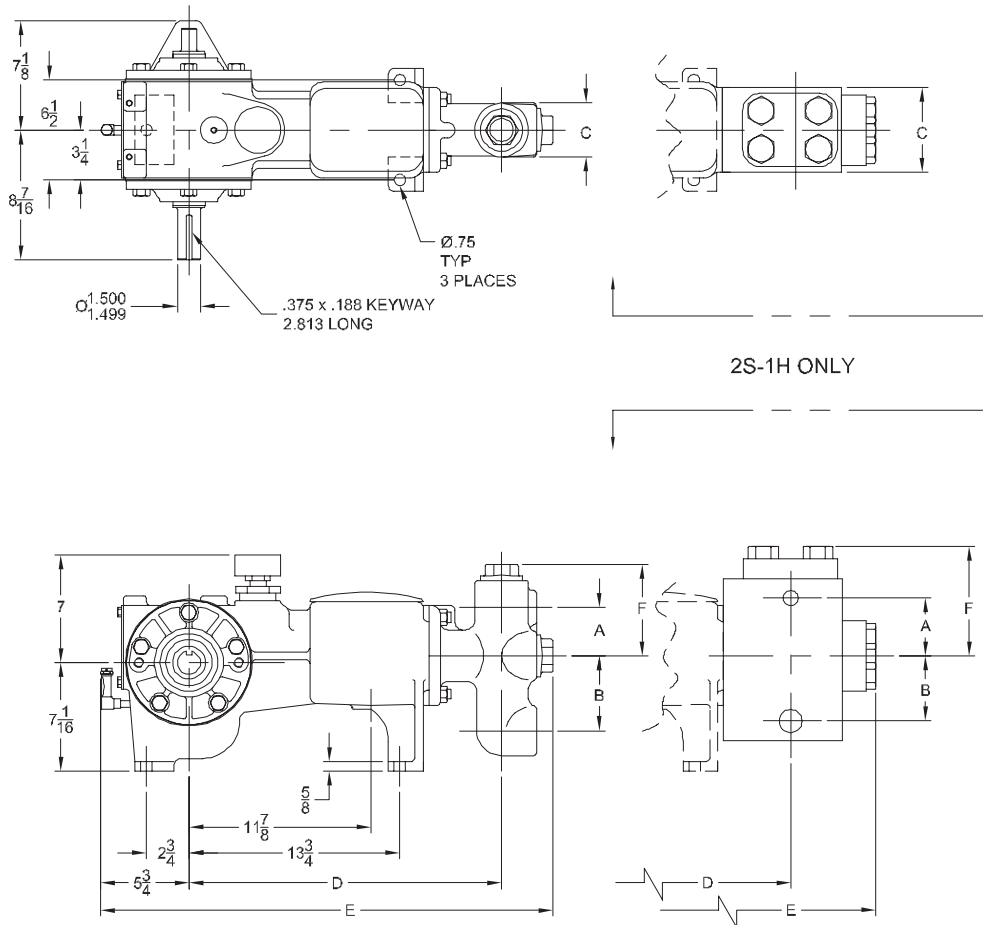

Specifications

- Pump Size:**
maximum plunger size x stroke length, in.(mm)
2.000 x 2.188 (50.8 x 55.56)
- Rated BHP (kW) at 350 RPM**
5.5 (4.1)
- Rated plunger load, pounds (kg)**
2030 (921)
- Maximum discharge pressure: psi (kPa)**
"L" model: 1149 (7920)
"M" model: 2042 (14081)
"H" model: 4595 (31681)
- Crankshaft extension:** in.(mm)
Diameter, in.(mm): 1.500 (38.1)
Length, in.(mm): 3.375 (85.73)
Keyway width x depth, in.(mm):
3/8 x 3/16 (9.53 x 4.76)
Maximum recommended sheave diameter,
in.(mm): 25 (635)
- For larger sizes: **Contact Factory**
- Oil Capacity, gallons (L)**
Crankcase: 1/2 (1.89)
- Weight, pump only on**
wood shipping skids, pounds (kg): 218 (99.1)
Weight varies with pump model
- Standard Materials for Fluid Ends:**
"L" & "M" models
Cast Ductile Iron
Cast Nickel-Aluminum-Bronze
Cast 316 Stainless Steel
Plate Carbon Steel
"H" model
Forged Carbon Steel
Forged 15-5 Stainless Steel

Pump Model	Flange Connections		Dimensions (Inches)					
	Discharge Connection Sizes	Suction Connection Sizes	A	B	C	D	E	F
5S-2L	1 (25.4)-11 1/2 FNPT	2 (50.8)-11 1/2 FNPT	3 1/8	4 7/8	3 1/2	20 3/8	29 9/16	5 15/16
5S-2M	1 (25.4)-11 1/2 FNPT	2 (50.8)-11 1/2 FNPT	3 1/8	4 7/8	3 1/2	20 3/8	29 9/16	5 15/16
5S-2H	3/4 (19.05)-14 FNPT	1 1/4 (31.75)-11 1/2 FNPT	3 3/4	4 1/4	5 1/2	20	31 5/16	7 1/8

5S-2 Simplex Plunger Pump

Performance Data

PUMP	English Units					50 RPM		150 RPM		200 RPM		250 RPM		300 RPM		350 RPM	
	Plunger Dia. In.	Plunger Area Sq. In.	BPD per RPM	GPM per RPM	Max. Press. PSI	BPD	GPM	BPD	GPM	BPD	GPM	BPD	GPM	BPD	GPM	BPD	GPM
5S-2L (P50ALS)	2.000	3.1416	1.0200	0.0297	646	51	1.49	153	4.46	204	5.95	255	7.44	306	8.92	357	10.41
	1.875	2.7612	0.8965	0.0261	735	45	1.31	135	3.92	180	5.23	225	6.54	269	7.84	314	9.15
	1.750	2.4053	0.7809	0.0228	844	40	1.14	118	3.42	157	4.56	196	5.69	235	6.83	274	7.97
	1.625	2.0739	0.6734	0.0196	979	34	0.98	102	2.95	135	3.93	169	4.91	203	5.89	236	6.87
	1.500	1.7671	0.5737	0.0167	1149	29	0.84	87	2.51	115	3.35	144	4.18	173	5.02	201	5.86
5S-2M (P50A)	1.750	2.4053	0.7809	0.0228	844	40	1.14	118	3.42	157	4.56	196	5.69	235	6.83	274	7.97
	1.625	2.0739	0.6734	0.0196	979	34	0.98	102	2.95	135	3.93	169	4.91	203	5.89	236	6.87
	1.500	1.7671	0.5737	0.0167	1149	29	0.84	87	2.51	115	3.35	144	4.18	173	5.02	201	5.86
	1.375	1.4849	0.4821	0.0141	1367	25	0.70	73	2.11	97	2.81	121	3.52	145	4.22	169	4.92
	1.250	1.2272	0.3984	0.0116	1654	20	0.58	60	1.74	80	2.32	100	2.91	120	3.49	140	4.07
5S-2H (P50H)	1.000	0.7854	0.2550	0.0074	2585	13	0.37	39	1.12	51	1.49	64	1.86	77	2.23	90	2.60
	0.875	0.6013	0.1952	0.0057	3376	10	0.28	30	0.85	40	1.14	49	1.42	59	1.71	69	1.99
	0.750	0.4418	0.1434	0.0042	4595	8	0.21	22	0.63	29	0.84	36	1.05	44	1.26	51	1.46
Brake Horsepower Required						0.8		2.3		4.0		3.9		4.7		5.5	

PUMP	Metric Units					50 RPM		150 RPM		200 RPM		250 RPM		300 RPM		350 RPM	
	Plunger Dia. mm	Plunger Area cm ²	M ³ /Hr per RPM	L/Sec. per RPM	Max. Press. kPa	M ³ /Hr	L/Sec.	M ³ /Hr	L/Sec.	M ³ /Hr	L/Sec.	M ³ /Hr	L/Sec.	M ³ /Hr	L/Sec.	M ³ /Hr	L/Sec.
5S-2L (P50ALS)	51	20.268	0.0068	0.0019	4455	0.34	0.09	1.01	0.28	1.35	0.38	1.69	0.47	2.03	0.56	2.36	0.66
	48	17.814	0.0059	0.0016	5069	0.30	0.08	0.89	0.25	1.19	0.33	1.48	0.41	1.78	0.49	2.08	0.58
	44	15.518	0.0052	0.0014	5819	0.26	0.07	0.78	0.22	1.03	0.29	1.29	0.36	1.55	0.43	1.81	0.50
	41	13.380	0.0045	0.0012	6749	0.22	0.06	0.67	0.19	0.89	0.25	1.12	0.31	1.34	0.37	1.56	0.43
5S-2M (P50A)	38	11.401	0.0038	0.0011	7920	0.19	0.05	0.57	0.16	0.76	0.21	0.95	0.26	1.14	0.32	1.33	0.37
	44	15.518	0.0052	0.0014	5819	0.26	0.07	0.78	0.22	1.03	0.29	1.29	0.36	1.55	0.43	1.81	0.50
	41	13.380	0.0045	0.0012	6749	0.22	0.06	0.67	0.19	0.89	0.25	1.12	0.31	1.34	0.37	1.56	0.43
	38	11.401	0.0038	0.0011	7920	0.19	0.05	0.57	0.16	0.76	0.21	0.95	0.26	1.14	0.32	1.33	0.37
	35	9.580	0.0032	0.0009	9426	0.16	0.04	0.48	0.13	0.64	0.18	0.80	0.22	0.96	0.27	1.12	0.31
5S-2H (P50H)	32	7.917	0.0026	0.0007	11405	0.13	0.04	0.40	0.11	0.53	0.15	0.66	0.18	0.79	0.22	0.92	0.26
	29	6.413	0.0021	0.0006	14081	0.11	0.03	0.32	0.09	0.43	0.12	0.53	0.15	0.64	0.18	0.75	0.21
	25	5.067	0.0017	0.0005	17821	0.08	0.02	0.25	0.07	0.34	0.09	0.42	0.12	0.51	0.14	0.59	0.16
	22	3.879	0.0013	0.0004	23276	0.06	0.02	0.19	0.05	0.26	0.07	0.32	0.09	0.39	0.11	0.45	0.13
5S-2H (P50H)	19	2.850	0.0010	0.0003	31681	0.05	0.01	0.14	0.04	0.19	0.05	0.24	0.07	0.29	0.08	0.33	0.09
	Kilowatts Required						0.6		1.7		3.0		2.9		3.5		4.1

For operation below 50 RPM, an auxiliary lubrication system is required.

Volumetric Rate is based on 100% Volumetric Efficiency. Brake Horsepower/Kilowatts Required is based on 72% Mechanical Efficiency.

The information and data on this sheet is accurate to the best of our knowledge and belief, but are intended for general information only. Applications suggested for the materials are described only to help readers make their own evaluations and decisions, and are neither guarantees nor to be construed as express or implied warranties of suitability for these or other applications. National Oilwell makes no warranty either express or implied beyond that stipulated in National Oilwell Standard Terms and Conditions of Sale.

Accessories

Rotating Right offers a full line of accessories to ensure long trouble free and safe operation of your multiplex pumps.

Accessories Include:

- Pulsation Dampeners - Suction & Discharge
- Vibration Shock Switches
- Liquid Level Gauges & Switches
- Pressure Safety Valves
- Plunger Lubricators
- Fire Safety Valves
- High Discharge Pressure Switch
- Condensate Drain
- N.A.C.E. Valving
- Lubricator Level Controller
- API Valves
- Drive Options



Expendables



With our worldwide buying power Rotating Right is well equipped to provide a wide range of replacement parts & expendables for virtually all multiplex plunger pumps regardless of make or model.

Our expendables inventory includes plungers, packing, brass, valves, bearings, crankshafts, connecting rods and seals.



Repair & Overhauls

Rotating Right service technicians follow strict quality control procedures for every pump repair and overhaul. The use of consistent and reliable re-manufacturing techniques ensure your equipment is returned to you in "Like New" condition.

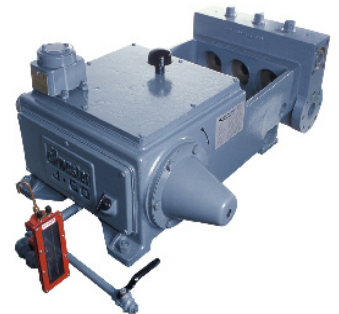

Head Office:
6120 Davies Road
Edmonton, AB
T6E 4M9

Phone: (780) 485-2010 • Toll Free: (866) 707-7867
Fax: (780) 485-1938
• Calgary • Drayton Valley • Lloydminster
www.rotatingright.com