

# Operating and Assembly Instruction Progressive Cavity Pump



24h Helpline:  
www.seepex.com

**Commission No.**

800000-800001

**Type**

BN 300-6L

**Job#**

XXX

Read instructions before  
beginning any work!

Always keep instructions  
handy on the worksite.

<b>1</b>	<b>Safety</b> .....	<b>1</b>
1.1	General Information	
1.2	Safety and warning notices	
1.2.1	Warning notices	
1.2.2	Hazard signs	
1.2.3	Information signs	
1.3	Hazards that may arise from the machine	
1.4	Qualification of personnel	
1.5	Authorised persons	
1.5.1	Tasks and information for the operating company / operator	
1.5.2	Safety information for maintenance, technical service and assembly work	
1.6	Equipment for personal protection	
1.7	Safety and protective devices	
1.8	Foreseeable misuse	
1.9	Normal usage	
1.10	Warranty	
<b>2</b>	<b>Description of the pump</b> .....	<b>5</b>
2.1	General description	
2.2	Mode of action and conveying principle of seepex pumps	
2.3	Construction	
<b>3</b>	<b>Technical Data</b> .....	<b>6</b>
3.1	Data sheet.....	7
3.2	Characteristic line.....	10
3.3	Declaration of conformity / Declaration by the manufacturer.....	11
<b>4</b>	<b>Transport</b> .....	<b>12</b>
4.1	Safety	
4.2	Transport	
4.2.1	Dimensions and weight	
4.2.2	Pictographs	
4.2.3	Jacking points (AP) for lifting gear	
4.2.4	Unpacking the machine	
4.3	Intermediate storage / preserving	
4.4	Disposal	

<b>5</b>	<b>Assembly / Installation</b> .....	<b>14</b>
5.1	Mounting tools / lifting gear	
5.2	Required space	
5.2.1	Stator construction dimensions	
5.3	Erection of the complete mounted pump	
5.4	Energy supply to the seepex pump	
5.5	Pipe work	
5.5.1	Suction and pressure connection	
5.5.2	Dimensioning of pipe work	
5.5.3	Residue-free pipe work	
5.5.4	Tension-free mounting	
5.6	Dimensional Drawing.....	16
<b>6</b>	<b>Commissioning / De-Commissioning</b> .....	<b>17</b>
6.1	Commissioning report.....	17
6.2	Measures before commissioning.....	18
6.2.1	Check pipe work	
6.2.2	Protective devices on the pump	
6.2.3	Electrical/hydraulic connections	
6.2.4	Monitoring the direction of rotation	
6.2.5	Auxiliary equipment – optional	
6.3	Initial commissioning / re-commissioning	
6.3.1	Avoiding dry running of the pump	
6.3.2	Pressure on the suction and pressure connection	
6.4	De-commissioning	
6.4.1	Switching the pump off	
6.4.2	Emptying the pump	
6.4.3	Dismantling the pump	
6.4.4	Preserving / placing pump in storage	
<b>7</b>	<b>Maintenance</b> .....	<b>22</b>
7.1	Preventative measures	
7.1.1	Standstill of the pump	
7.2	Lubrication	
7.2.1	Joint grease	
7.3	Technical service	
<b>8</b>	<b>Faults, causes and repair</b> .....	<b>24</b>
<b>9</b>	<b>Pump dismantling / reassembly</b> .....	<b>26</b>
9.1	Pump.....	26
9.1.1	Prepare the pump for dismantling	
9.1.2	Dismantling	
9.1.3	Reassembly	

9.2	Rotating unit – individual parts .....	31
9.2.1	Dismantling	
9.2.2	Prepare individual parts for reassembly	
9.2.3	Reassembly	
9.3	Holding band - assembly.....	35
9.3.1	Prepare the holding band	
9.3.2	Check the holding band	
9.3.3	Assembling the holding band	
9.3.4	Correct tension for the holding band	
9.3.5	Cant the holding band	
9.3.6	Shear the holding band	
9.3.7	Check the holding band after assembly	
9.4	Mechanical seal .....	37
9.4.1	Safety	
9.4.2	Application conditions and material version	
9.4.3	Design	
9.4.4	Commissioning	
9.4.5	Monitoring during operation	
9.4.6	Dismantling of mechanical seal	
9.4.7	Reassembly of mechanical seal	
9.6	Sectional drawing shaft sealing.....	40
<b>10</b>	<b>Spare parts.....</b>	<b>41</b>
10.1	Order template for spare parts.....	42
10.2	Sectional drawing and parts list.....	45
<b>11</b>	<b>Special tools.....</b>	<b>48</b>
11.1	Master copy tools	
<b>12</b>	<b>Related documents.....</b>	<b>49</b>
12.1	Accessories .....	50
12.2	Technical Information.....	58
<b>13</b>	<b>Annex.....</b>	<b>61</b>
13.1	Manufacturer’s documents from sub-supplier	
13.1.1	gearbox.....	62
13.1.2	Motor .....	73

**Subsidiaries**

1.1 General notes

- Always keep the operating and maintenance instructions close by the machine.
- If problems cannot be solved with reference to the operating and maintenance instructions, please contact the manufacturer.

Observe the following points in addition to these operating and maintenance instructions:



- Prohibition, warning and mandatory signs, warning notes on the machine
- Relevant laws and ordinances
- Statutory provisions on accident prevention
- Corresponding harmonised standards and regulations

1.2 Safety and warning notes

- Comply with safety and warning notes for safe and efficient use of the product.

Signal words for specific dangers and (possible) consequences are explained below. These are supplemented by symbols (pictograms) if necessary.

1.2.1 Warning notes

<b>NOTICE</b>	
<b>Caution for machine!</b> Possible danger. Material damage can occur.	
	<b>CAUTION</b>
<b>Caution for people and machine!</b> Possible danger. Minor injury or damage to property can occur.	
	<b>WARNING</b>
<b>Warning for people!</b> Possible danger. Death or serious injury can occur.	
	<b>DANGER</b>
<b>Danger for people!</b> Possible danger. Immediate risk of sever or fatal injury.	

1.2.2 Danger symbols



Warning:  
Suspended load



Warning:  
Tipping over

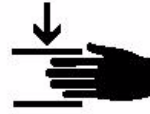

Warning:  
Hand injuries



Warning:  
Dangerous electrical  
voltage.



Warning:  
Pull-in hazard.



Warning:  
Excess pressure.



Warning:  
Risk to the environ-  
ment.



Warning:  
Hot surfaces.

1.2.3 Information symbols



Observe operating  
and maintenance  
instructions.

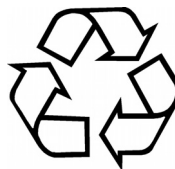

Ensure environmen-  
tal protection.

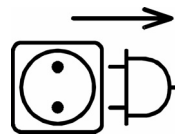

Disconnect power  
plug before opening.



Wear eye protection.



Wear gloves.

- Instruction to act/take measures
- List item

### 1.3 Dangers that can be caused by the machine

seepex machines are built in accordance with the state of the art.

Nevertheless, there is a residual risk, because the machine works with:

- Mechanical movements that pose a danger
- Electrical voltages and currents

We have used design measures and applied safety technology to minimise the risk to the health of people posed by this danger.

### 1.4 Qualification of the personnel

This handbook is intended for:

- Owner
- Operators
- Setters
- Maintenance personnel

### 1.5 Authorised people

People authorised to undertake operation, set up and maintenance are instructed and trained specialists employed by the owner/manufacturer.



Detailed technical knowledge is essential for performing any work on the machine.

The owner is responsible for:

- Personnel training
- Compliance with safety regulations
- Compliance with operating and maintenance instructions

The operator must:

- Have received instruction
- Read and understood the relevant parts of the operating instructions before starting work
- Know the safety devices and regulations

#### 1.5.1 Tasks and information for the owner/operators

- Regularly check and maintain the machine, replacing all parts in good time which no longer guarantee safe operation.
- It is essential to comply with the procedure described in the operating instructions for shutting down the machine.
- On completion of work, attach all safety and protective devices and make sure they are functioning.

#### 1.5.2 Safety notes for maintenance, inspection and assembly work

- Do not work on the machine or system unless it is stationary and depressurised.
- Switch off the master switch and pull out the power plug before starting work on live components.
- Comply with the procedure for shutting down the machine as described in the Shut-down chapter.
- Decontaminate (de-toxify) machines that are used for pumping media that can be harmful to health.
- Refer to the Initial start-up chapter before repeated start-up of the machine.

**1.6 Personal protective equipment**

- Wear personal protective equipment and/or additional equipment for your own safety.
- Avoid/limit risks by the use of collective technical protective equipment or by organisational measures at work.

**1.7 Safety and protective devices**

- Prior to start-up, bolt seepex machines onto a concrete foundation so as to ensure stability.
- Starting and stopping devices must be clearly recognisable. Take appropriate measures to avoid defects.
- No protective device is necessary for checking and/or setting the shaft seal.
- Hot surfaces are identified with a danger symbol on the machine.

**1.8 Foreseeable misuse**

Serious personal injury and damage to property can be caused by:

- Incorrect use
- Incorrect installation or operation of the machine
- Impermissible removal of necessary protective equipment

**1.9 Designated use**

- Only use seepex machines if they are in perfect condition and in compliance with the operating and maintenance instructions.
- Do not start up the machine unless the system in which the machine is installed is in accordance with the provisions of the applicable guidelines and statutory regulations.
- Equivalent sustained sound pressure level at workplaces of operating personnel C75 dB (A). Cavitation-free operation of the machine and screwed connection to concrete foundation are essential.
- seepex machines are components that are exclusively intended for pumping media in accordance with the technical data (chapter 3.0). Written approval must be obtained from the manufacturer before other media are pumped.
- Refer to the information on the type plate and the operating instructions for technical data (chapter 3.0), and comply with them.
- The operating instructions are assigned to the seepex machine based on the commission number.



Fig. 1-1 Similar illustration

**1.10 Statutory guarantee**

- Warranty in accordance with our terms and conditions of delivery and order confirmation.
- It is a condition of the machine warranty that the machine must correspond to the listed operating instructions in accordance with the type plate/data sheet.
- All wearing parts are excluded from the warranty.
- These operating instructions are subject to copyright. Reproduction is not permitted and will be punished. Contravention will be pursued through the courts.

**2.1 General description**

seepex pumps are members of the group of rotating displacement pumps.

- Characteristic features
  - Special configuration/arrangement of the rotor and stator pumping elements.
  - Motion sequence

**2.2 Mode of action and pumping principle of the seepex pump**

- Seal lines are created by the geometrical configuration/contact between both pumping elements.
- Seal lines provide total separation between the suction and pressure sides.

Result:

- Increased suction lift capability of the pump
- High pressure build-up irrespective of the rotation speed

**2.3 Constructive design**

No.	Designation
ANT	Drive
200	Lantern
307	Plug-in shaft
400	Coupling rod
SEA	Shaft seal
500	Suction casing
600	Rotor
RTE	Rotating unit
601	Stator
700	Pressure branch

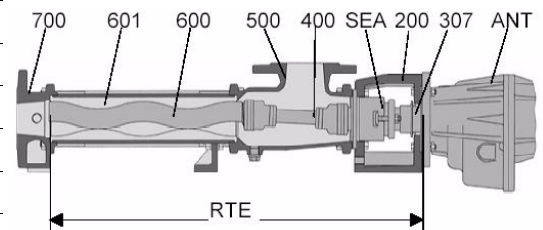

3.1 Data sheet

3.2 Characteristic

3.3 Declaration of conformity / declaration by the manufacturer

**Data Sheet**

seepex  
order no. commission no.  
date

customer  
purchase order no. item/denomination  
project

\_ of \_ seepex progressive cavity pump  
type BN \_- / A1-A7-A7-F0-GAM3.2-X

conveying product  
denomination  
rate of solids t viscosity  
size of solids pH-value  
specific gravity temperature  
composition  
remarks

<b>performance data</b>	nom.	min	max	
conveying capacity				m3/h
pump speed				rpm
press in press. branch				bar
press in suct. branch				
differential pressure	bar		operating torque	Nm
required drive power	kW		starting torque	Nm
remarks				

**technical pump data**  
range kind of install.  
size direction of rot.  
pressure stage pos. of branch

<u>component</u>	<u>material</u>	<u>design/option</u>
lantern		
suction casing		
suction connection		
pressure branch		
pressure connection		
joint		
joint grease		
joint seal		
coupling rod		
rotor		
stator		
mechanical seal casing		
mechanical seal		
plug-in shaft		
special designs		

**Data Sheet**

**Page 2**

**general operating data**

kind of operation  
site of installation  
remarks

**drive**

type		
make	ratio	
model		
mounting position		nom./ min - max
flange dia	output speed	
output shaft	motor speed	
	frequency	
type of adjustment		
speed transmitter		
speed indication		
special/accessories		

**electric motor**

make	model
nominal power	voltage
nominal speed	rated frequency
mounting position	protection
starting	thermal class
	size
	flange/shaft dia.
	fitting of motor

provid. of motor

**baseplate**

standard	material
drawing no.	surface
special/accessories	

**painting**

execution  
color  
remarks

**packing**

packing type  
marking

**documentation**

dimensional drawing no.	operating manual
sectional drawing no.	
shaft sealing sect. view	

**QA-documentation**

## EC Declaration of Conformity

complying with the Machinery Directive 98/37/EC, Appendix II A

Manufacturer: seepex GmbH  
Address: Scharnhölzstrasse 344  
D-46240 Bottrop

We hereby declare that the following product

### Progressive cavity pump

of ranges

- **BN, BE, BK, BS, BC, BCSB, BCSO, BW, BA, MD, MDC, MDF, MDP**
  - as block pump complete **with** flanged drive

and ranges

- **NS, N, S, C, CSB, CSO**
  - as pump with free shaft, **with** drive
  - as pump **with** drive preassembled on a common baseplate

meets the regulations of the above mentioned directive as well as its amendments which are valid at the time of declaration.

The following harmonized standards are applicable:

DIN EN ISO 12100-1	Safety of machinery Part 1
DIN EN ISO 12100-2	Safety of machinery Part 2
DIN EN 294	Safety distances to prevent danger zones being reached by the upper limbs
DIN EN 809	Pumps and pump units for liquids
DIN EN 811	Safety distances to prevent danger zones being reached by the lower limbs

The accompanying operating instruction includes important safety advices and rules for installation, commissioning and maintenance of the seepex machinery.

The safeguarding of the machinery against inadmissible pressure, dry running and wrong direction of rotation must be ensured at site.

Bottrop, 16.09.2005



i.V. Klemens Fockenber  
Manager Engineering  
seepex GmbH



i.V. Roland Hecker  
Manager Quality Assurance  
seepex GmbH

## EC Declaration by the Manufacturer

as defined by the Machinery Directive 98/37/EC, Annex II B

Manufacturer: seepex GmbH

Address: Scharnhölzstrasse 344  
D-46240 Bottrop

We hereby declare that the following product

### Progressive cavity pump

of the ranges

- **BN, BE, BK, BS, BC, BCSB, BCSO, BW, BA, MD, MDC, MDF, MDP**
  - as block pump **without** flanged drive

as well as

- **NS, N, S, C, CSB, CSO**
  - as pump with free shaft **without** drive
  - as pump preassembled on a baseplate, **without** drive

meets the regulations of the above mentioned directive as well as its amendments which are valid at the time of declaration.

The following harmonized standards are applicable:

DIN EN ISO 12100-1	Safety of machinery Part 1
DIN EN ISO 12100-2	Safety of machinery Part 2
DIN EN 294	Safety distances to prevent danger zones being reached by the upper limbs
DIN EN 809	Pumps and pump units for liquids
DIN EN 811	Safety distances to prevent danger zones being reached by the lower limbs

The accompanying operating instruction includes important safety advices and rules for installation, commissioning and maintenance of the seepex machinery.

The safeguarding of the machinery against inadmissible pressure, dry running and wrong direction of rotation must be ensured at site.

Bottrop, 03.06.2004



i.V. Klemens Fockenbergh  
Manager Engineering  
seepex GmbH



i.V. Roland Hecker  
Manager Quality Assurance  
seepex GmbH

4.1 Safety

 <b>CAUTION</b>
<p><b>Damage to property/injuries due to incorrect transport.</b> Slight injury or damage to property can occur.</p> <ul style="list-style-type: none"> <li>➤ Comply with the safety notes and transport notes on the packaging.</li> <li>➤ Use suitable means of transport, lifting devices and tools.</li> <li>➤ Use protective equipment.</li> </ul>

4.2 Transport

4.2.1 Dimensions, weight and centre of gravity



- Note the dimensional drawing (chapter 5.6).

4.2.2 Symbol

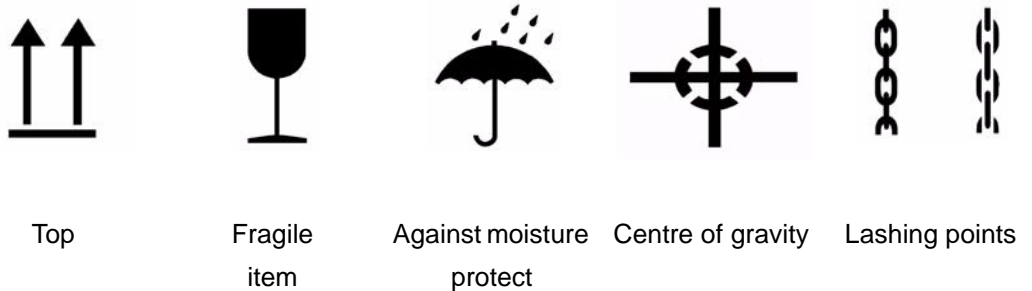
- Meaning of symbol



4.2.3 Lashing points (AP) for lifting devices

	 <b>WARNING</b>
	<p><b>Warning of suspended load.</b> Death or serious injury can occur.</p> <ul style="list-style-type: none"> <li>➤ Use the lashing points (AP) for lifting devices.</li> </ul>

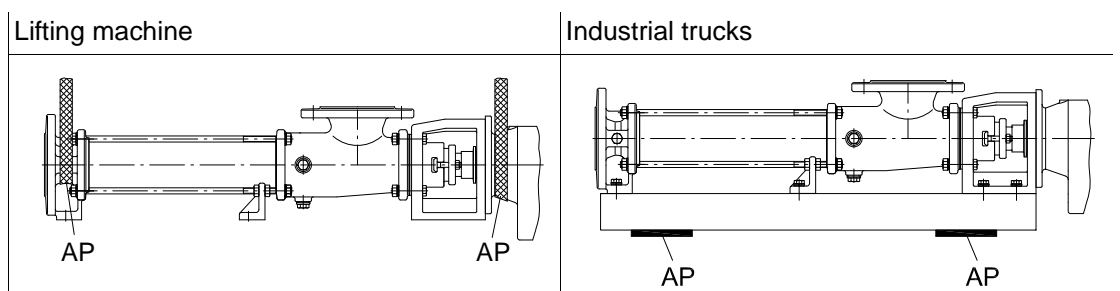

4.2.4 Unpacking the machine

- Comply with the symbols and notices on the packaging.
- Remove the screwed connection between the machine and packaging.
- Remove the machine with a lifting machine/industrial truck.

#### 4.3 Temporary storage/corrosion protection

- All seepex machines have corrosion protection applied as standard prior to transport.

##### NOTICE

**Damage to property if corrosion protection is missing.**

Property damage can occur due to corrosion.

- Temporary storage must be in a dry, enclosed, frost-free room in order to provide protection against ambient influences.
- Contact seepex regarding the necessary corrosion protection for temporary storage.

#### 4.4 Disposal



##### NOTICE

**Environmental protection.**

Material damage can occur.

- Drain the pumping medium and dispose of it in accordance with the regulations.
- Dispose of the machine with regard to its composition and existing regulations.

5.1 Mounting tools / lifting gear

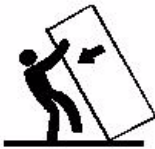
	<p><b>⚠ CAUTION</b></p>
	<p><b>Pump falling over.</b> Slight injury or damage to property can occur.</p> <ul style="list-style-type: none"> <li>➤ Adhere to the lifting tool's starting point.</li> <li>➤ Pay attention to the dimensions, weight and centre of gravity of the pump.</li> <li>➤ Use suitable mounting tools/lifting gear.</li> </ul>

5.2 Space requirement

The required space should be determined by considering the following factors:

- Dimensions and weight.
- Requisite transport and lifting equipment.
- Pipe routing – dismantling (dimension for stator replacement).

5.2.1 Dimension for stator replacement (P)

- Refer to the dimensional drawing.

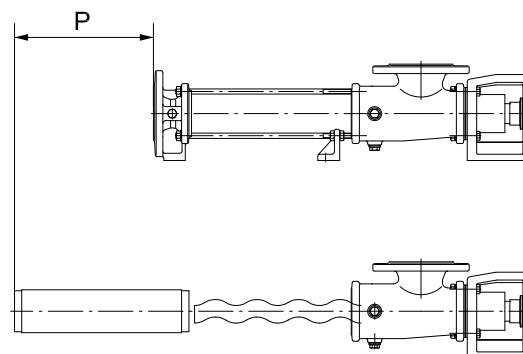

5.3 Assembly of the complete mounted pump

- Assemble according to technical data (chapter 3.).
- Note dimensional drawing.

**Tension-free mounting of the pump**



- Balance unevenness with suitable supports.
- Applies to mounting on foundations/load-bearing elements.
- Total areas of all pump bearing areas are resting on the surface.

**Correct position of the drives**

- All drives are set up ready for operation and mounted.
- Correct displacements of the drive during transport/installation of the pump by adjusting/fixing the drive.

	<p><b>⚠ CAUTION</b></p>
	<p><b>Safety protection devices.</b> Slight injury or damage to property may result.</p> <ul style="list-style-type: none"> <li>➤ Connect safety protection devices and activate.</li> </ul>

## 5.4 Power supply of the seepex pump

	 <b>DANGER</b>
	<p><b>Line voltage and line frequency.</b> Death or serious injury can occur.</p> <ul style="list-style-type: none"> <li>➤ Note type plate on the pump.</li> <li>➤ Pay attention to manufacturer's directions (chapter 13.).</li> <li>➤ Pay attention to safety regulations.</li> </ul>

## 5.5 Pipelines

## 5.5.1 Suction and pressure connection

- Refer to the dimensional drawing for the position, nominal width and standard.
- Note direction of rotation/flow direction.

## 5.5.2 Pipeline dimensions

- Adhere to specifications regarding pressure in the pressure respectively suction connection.
- Note technical data (chapter 3.).
- Nominal width of suction pipe = nominal width of suction connection of pumps.

## 5.5.3 Residue-free pipelines

<i>NOTICE</i>
<p><b>Damage to property through assembly residue.</b> No claims under guarantee if violated.</p> <ul style="list-style-type: none"> <li>➤ Keep all pipelines free of foreign objects.</li> <li>➤ Remove weld spatters, screws, steel chips etc.</li> </ul>

## 5.5.4 Tension-free assembly

- Assemble pipelines and other components in a tension-free manner on the pump.

**Master Copy**

**6.1 Commissioning report**

Send commissioning report online to  
www.seepex.com/Inbetriebnahme/

**Must be specified with every order!**

**Commission:**

\_\_\_\_\_

**Model:**

\_\_\_\_\_

**From:**

Contact person: .....

Tel.: .....

Fax: .....

E-mail: .....

**Customer Service:**

seepex GmbH  
Postfach 10 15 64  
D-46215 Bottrop  
service@seepex.com

**Germany**

**Rest of Europe**

**Outside Europe**

Phone:+49 2041.996-231

Fax: +49 2041.996-431

Phone:+49 2041.996-224

Fax: +49 2041.996-424

Phone:+49 2041.996-120

Fax: +49 2041.996-432

**Address of plant:**

.....

.....

.....

.....

.....

Delivery date:

Date of installation:

Assembly check carried out on:

**Please enter operational data:**

Conveying liquid:

Temperature:

Fuse level/motor protection or power consumption

Frequency control

no

yes

If yes:

Supplied by seepex

Supplied by customer

Frequency:

Speed:

Power consumption:

Place, date

Signature / company stamp

**6.2 Measures before commissioning**

- Note the technical data (chapter 3.).

**6.2.1 Checking pipelines**

- Check flange screwed connections (SCH).

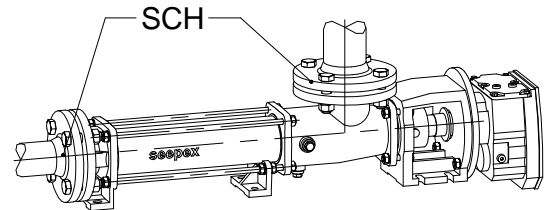

- Check threaded connections (G).

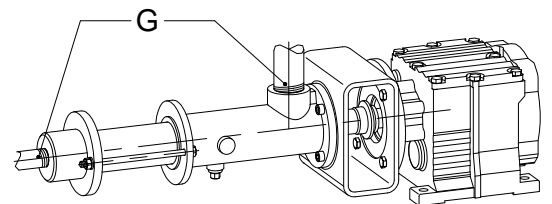

<b>NOTICE</b>
<p><b>Ensure the liquid can flow through without obstruction.</b> Malfunction and/or irreparable damage to the pump.</p> <ul style="list-style-type: none"> <li>➤ Open all shut-off elements before switching on the pump.</li> </ul>

**6.2.2 Protective devices on the pump**

	<b>DANGER</b>
	<p><b>Missing protective device.</b> Danger of pulling in and crushing.</p> <ul style="list-style-type: none"> <li>➤ Equip the pump with a protective device. Protective devices provided for preventing contact with surfaces or moving parts must be regarded as suitable if contact is not possible in a test involving a test finger, with regard to the penetration possibility, strength and shock resistance.</li> <li>➤ Comply with national protection regulations.</li> <li>➤ In pumps with an open suction flange/feed hopper, attach touch protection. These safety clearances protect those persons who are attempting to reach danger areas without additional help and under the conditions defined for various situations of reaching up, reaching under or reaching through</li> </ul> <p>In shaft seals, touch protection is only necessary if there are components on the rotating shaft.</p>

**6.2.3 Electrical/hydraulic connections**

	<b>DANGER</b>	
	<p><b>Dangerous voltage.</b> Death or serious injury can occur.</p> <ul style="list-style-type: none"> <li>➤ Observe safety regulations.</li> <li>➤ Disconnect the pump from all sources of energy.</li> <li>➤ Prevent electrical connections from being switched on again.</li> </ul>	

**6.2.4 Direction of rotation check**

- The pump direction of rotation determines the flow direction of the pumping medium.
- Note the direction of rotation arrow on the type plate.

flow direction



counter clockwise

clockwise

**6.2.5 Additional devices - optional**

- Refer to additional devices (chapter 12.1).

**6.3 Initial commissioning/repeated commissioning**

- Start up the pump.

<b>NOTICE</b>
<p><b>Dry running of the pump.</b> Malfunction and/or irreparable damage to the pump.</p> <ul style="list-style-type: none"> <li>➤ Fill the suction casing with liquid in order to lubricate the pumping elements.</li> </ul>

**6.3.1 Avoid dry running of the pump**

<b>NOTICE</b>
<p><b>High temperature between rotor and stator.</b> Stator material burned. Complete failure of the pump</p> <ul style="list-style-type: none"> <li>➤ Make sure that the suction-side conveying capacity does not cavitate.</li> <li>➤ If this cannot be guaranteed on the machine side, assemble a seepex dry running protection (DRP)</li> </ul>

**6.3.2 Pressure in the suction and pressure connection**

	<b>CAUTION</b>
	<p><b>High pressure.</b> Malfunction and/or irreparable damage to the shaft seal or pump.</p> <ul style="list-style-type: none"> <li>➤ Maintain pressure in the suction connection in accordance with the technical data (chapter 3.).</li> <li>➤ Assemble an oil-filled contact pressure gauge to monitor and deactivate the pump.</li> </ul>

**6.4 De-commissioning**

Protect the pump and additional devices against the following:

- Frost
- Deposit of solids
- Sedimentation from the liquid
- Corrosion of parts that come into contact with the medium

6.4.1 Switching off the pump

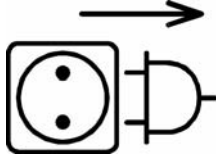
	<b>! DANGER</b>	
	<p><b>Dangerous voltage.</b> Death or serious injury can occur.</p> <ul style="list-style-type: none"> <li>➤ Observe safety regulations.</li> <li>➤ Disconnect the pump from all sources of energy.</li> <li>➤ Prevent electrical connections from being switched on again.</li> </ul>	

6.4.2 Emptying the pump

<b>! CAUTION</b>
<p><b>Liquid draining out.</b> Minor injury or damage to property can occur.</p> <ul style="list-style-type: none"> <li>➤ Wear suitable protective clothing.</li> <li>➤ Refer to the technical data (chapter 3.) for the corresponding configuration of the pump housing.</li> </ul>

To drain the pump:

- If the pump housing has screwed plugs, remove the screwed plugs.
- Drain using a connection branch (suction casing, pressure branch) if the pump housing is coated or the housing does not have screwed plugs.
- Drain the residual liquid from the pump housing.
- Drain the pipelines on the suction and pressure sides, or shut off behind the pump connections.

6.4.3 Removing the pump

	<b>! WARNING</b>
	<p><b>Risk of pump tipping or falling.</b> Death or serious injury can occur.</p> <ul style="list-style-type: none"> <li>➤ Support the drive unit to guarantee stability.</li> </ul>

**Pipeline dismantling**

- Remove flange bolts (SCH) and flange seals (DFL).  
with/without base plate
- Remove bolts (SCH) from the pump feet.

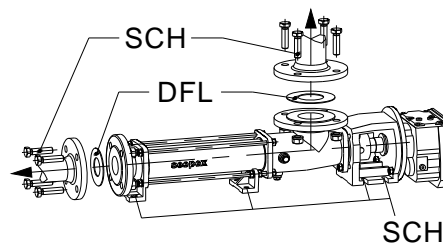

**Pipeline dismantling**

- Remove threaded connections (G).  
with/without base plate
- Remove bolts (SCH) from the pump feet.

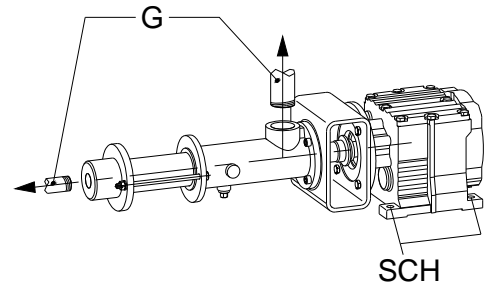
**6.4.4 Preservation/storage of the pump****NOTICE****Damage to property due to lack of corrosion protection.**

Property damage can occur due to corrosion.

- Contact seepex to discuss suitable preservation measures.
  - State the commission number of the pump.

7.1 Preventive measures



The maintenance personnel must have these operating instructions, follow them and also require corresponding qualifications.

- No liability will be accepted in the event of violation.

	<b>DANGER</b>	
	<p><b>Dangerous voltage.</b> Death or serious injury can occur.</p> <ul style="list-style-type: none"> <li>➤ Observe safety regulations.</li> <li>➤ Disconnect the pump from all sources of energy.</li> <li>➤ Prevent electrical connections from being switched on again.</li> </ul>	

7.1.1 Pump down-time

<p><b>NOTICE</b></p>
<p><b>Pump down-time.</b> Production failure due to wear.</p> <ul style="list-style-type: none"> <li>➤ Acquisition of a set of wearing parts and a set of gaskets.</li> </ul>

7.2 Lubrication

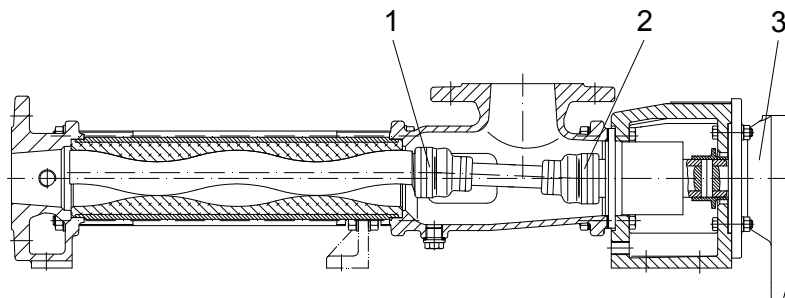

No.	Denomination	Lubricant	Lubricant change in operating hours	Fill volume
1	Pin joint	seepex special grease (30321)	10000 h	7 cm <sup>3</sup>
2	Pin joint	seepex special grease (30321)	10000 h	7 cm <sup>3</sup>
3	Drive	Refer to manufacturer's documentation (chapter 13.1)		
Rotor/stator		Conveying medium	---	---
Shaft seal		Conveying medium	---	---

7.2.1 Joint grease

<p><b>NOTICE</b></p>
<p><b>Other grease types.</b> Malfunction and/or irreparable damage to the joints or the pump.</p> <ul style="list-style-type: none"> <li>➤ Exclusively use seepex special grease.</li> </ul>

## 7.3 Inspection

Component	Interval	Action
Joints	Every 10,000 operating hours	Renew joint grease
Shaft seal	Every week	Visual check for leaks
Drive unit	Every 3000 operating hours, at least every 6 months	Comply with manufacturer's documentation

7.1 Preventive measures



The maintenance personnel must have these operating instructions, follow them and also require corresponding qualifications.

- No liability will be accepted in the event of violation.

	<b>DANGER</b>	
	<p><b>Dangerous voltage.</b> Death or serious injury can occur.</p> <ul style="list-style-type: none"> <li>➤ Observe safety regulations.</li> <li>➤ Disconnect the pump from all sources of energy.</li> <li>➤ Prevent electrical connections from being switched on again.</li> </ul>	

7.1.1 Pump down-time

<p><b>NOTICE</b></p>
<p><b>Pump down-time.</b> Production failure due to wear.</p> <ul style="list-style-type: none"> <li>➤ Acquisition of a set of wearing parts and a set of gaskets.</li> </ul>

7.2 Lubrication

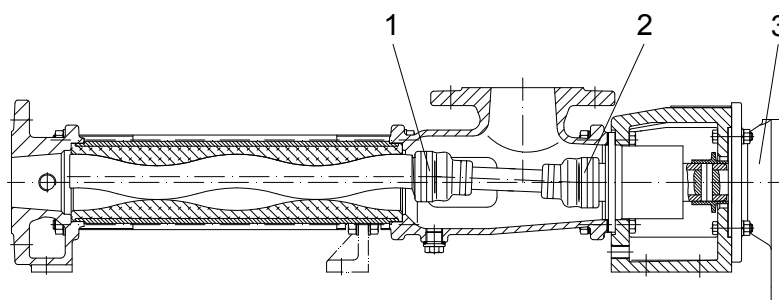

No.	Denomination	Lubricant	Lubricant change in operating hours	Fill volume
1	Pin joint	seepex special grease (30321)	10000 h	14 cm <sup>3</sup>
2	Pin joint	seepex special grease (30321)	10000 h	14 cm <sup>3</sup>
3	Drive	Refer to manufacturer's documentation (chapter 13.1)		
Rotor/stator		Conveying medium	---	---
Shaft seal		Conveying medium	---	---

7.2.1 Joint grease

<p><b>NOTICE</b></p>
<p><b>Other grease types.</b> Malfunction and/or irreparable damage to the joints or the pump.</p> <ul style="list-style-type: none"> <li>➤ Exclusively use seepex special grease.</li> </ul>

## 7.3 Inspection

Component	Interval	Action
Joints	Every 10,000 operating hours	Renew joint grease
Shaft seal	Every week	Visual check for leaks
Drive unit	Every 3000 operating hours, at least every 6 months	Comply with manufacturer's documentation

7.1 Preventive measures



The maintenance personnel must have these operating instructions, follow them and also require corresponding qualifications.

- No liability will be accepted in the event of violation.

	⚠ DANGER	
	<p><b>Dangerous voltage.</b> Death or serious injury can occur.</p> <ul style="list-style-type: none"> <li>➤ Observe safety regulations.</li> <li>➤ Disconnect the pump from all sources of energy.</li> <li>➤ Prevent electrical connections from being switched on again.</li> </ul>	

7.1.1 Pump down-time

NOTICE
<p><b>Pump down-time.</b> Production failure due to wear.</p> <ul style="list-style-type: none"> <li>➤ Acquisition of a set of wearing parts and a set of gaskets.</li> </ul>

7.2 Lubrication

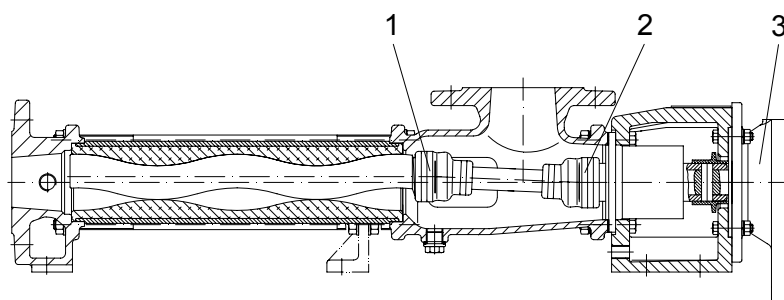

No.	Denomination	Lubricant	Lubricant change in operating hours	Fill volume
1	Pin joint	seepex special grease (30321)	10000 h	19 cm <sup>3</sup>
2	Pin joint	seepex special grease (30321)	10000 h	19 cm <sup>3</sup>
3	Drive	Refer to manufacturer's documentation (chapter 13.1)		
Rotor/stator		Conveying medium	---	---
Shaft seal		Conveying medium	---	---

## 7.2.1 Joint grease

**NOTICE****Other grease types.**

Malfunction and/or irreparable damage to the joints or the pump.

- Exclusively use seepex special grease.

## 7.3 Inspection

Component	Interval	Action
Joints	Every 10,000 operating hours	Renew joint grease
Shaft seal	Every week	Visual check for leaks
Drive unit	Every 3000 operating hours, at least every 6 months	Comply with manufacturer's documentation

7.1 Preventive measures



The maintenance personnel must have these operating instructions, follow them and also require corresponding qualifications.

- No liability will be accepted in the event of violation.

	<b>DANGER</b>	
	<p><b>Dangerous voltage.</b> Death or serious injury can occur.</p> <ul style="list-style-type: none"> <li>➤ Observe safety regulations.</li> <li>➤ Disconnect the pump from all sources of energy.</li> <li>➤ Prevent electrical connections from being switched on again.</li> </ul>	

7.1.1 Pump down-time

<b>NOTICE</b>
<p><b>Pump down-time.</b> Production failure due to wear.</p> <ul style="list-style-type: none"> <li>➤ Acquisition of a set of wearing parts and a set of gaskets.</li> </ul>

7.2 Lubrication

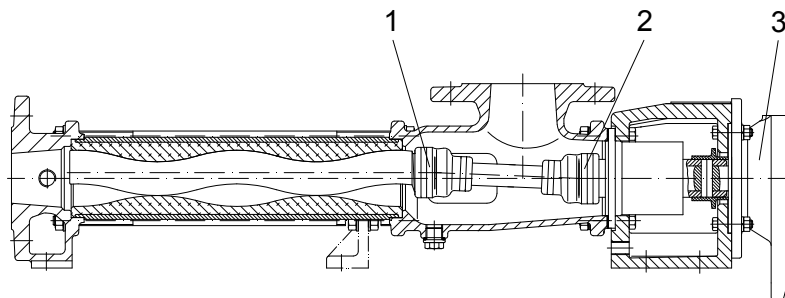

No.	Denomination	Lubricant	Lubricant change in operating hours	Fill volume
1	Pin joint	seepex special grease (30321)	10000 h	32 cm <sup>3</sup>
2	Pin joint	seepex special grease (30321)	10000 h	32 cm <sup>3</sup>
3	Drive	Refer to manufacturer's documentation (chapter 13.1)		
Rotor/stator		Conveying medium	---	---
Shaft seal		Conveying medium	---	---

7.2.1 Joint grease

<b>NOTICE</b>
<p><b>Other grease types.</b> Malfunction and/or irreparable damage to the joints or the pump.</p> <ul style="list-style-type: none"> <li>➤ Exclusively use seepex special grease.</li> </ul>

## 7.3 Inspection

Component	Interval	Action
Joints	Every 10,000 operating hours	Renew joint grease
Shaft seal	Every week	Visual check for leaks
Drive unit	Every 3000 operating hours, at least every 6 months	Comply with manufacturer's documentation

7.1 Preventive measures



The maintenance personnel must have these operating instructions, follow them and also require corresponding qualifications.

- No liability will be accepted in the event of violation.

	<b>! DANGER</b>	
	<p><b>Dangerous voltage.</b> Death or serious injury can occur.</p> <ul style="list-style-type: none"> <li>➤ Observe safety regulations.</li> <li>➤ Disconnect the pump from all sources of energy.</li> <li>➤ Prevent electrical connections from being switched on again.</li> </ul>	

7.1.1 Pump down-time

<b>NOTICE</b>
<p><b>Pump down-time.</b> Production failure due to wear.</p> <ul style="list-style-type: none"> <li>➤ Acquisition of a set of wearing parts and a set of gaskets.</li> </ul>

7.2 Lubrication

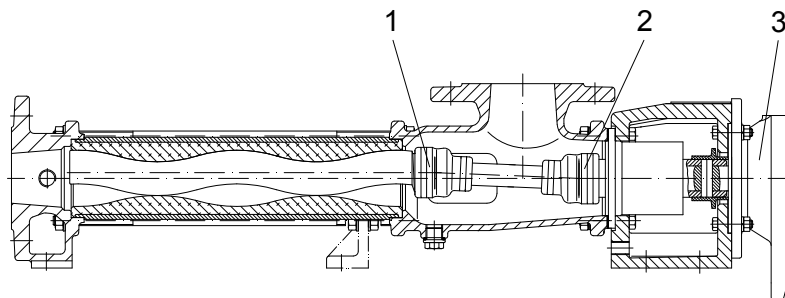

No.	Denomination	Lubricant	Lubricant change in operating hours	Fill volume
1	Pin joint	seepex special grease (30321)	10000 h	50 cm <sup>3</sup>
2	Pin joint	seepex special grease (30321)	10000 h	50 cm <sup>3</sup>
3	Drive	Refer to manufacturer's documentation (chapter 13.1)		
Rotor/stator		Conveying medium	---	---
Shaft seal		Conveying medium	---	---

7.2.1 Joint grease

<b>NOTICE</b>
<p><b>Other grease types.</b> Malfunction and/or irreparable damage to the joints or the pump.</p> <ul style="list-style-type: none"> <li>➤ Exclusively use seepex special grease.</li> </ul>

## 7.3 Inspection

Component	Interval	Action
Joints	Every 10,000 operating hours	Renew joint grease
Shaft seal	Every week	Visual check for leaks
Drive unit	Every 3000 operating hours, at least every 6 months	Comply with manufacturer's documentation

7.1 Preventive measures



The maintenance personnel must have these operating instructions, follow them and also require corresponding qualifications.

- No liability will be accepted in the event of violation.

	<b>! DANGER</b>	
	<p><b>Dangerous voltage.</b> Death or serious injury can occur.</p> <ul style="list-style-type: none"> <li>➤ Observe safety regulations.</li> <li>➤ Disconnect the pump from all sources of energy.</li> <li>➤ Prevent electrical connections from being switched on again.</li> </ul>	

7.1.1 Pump down-time

<b>NOTICE</b>
<p><b>Pump down-time.</b> Production failure due to wear.</p> <ul style="list-style-type: none"> <li>➤ Acquisition of a set of wearing parts and a set of gaskets.</li> </ul>

7.2 Lubrication

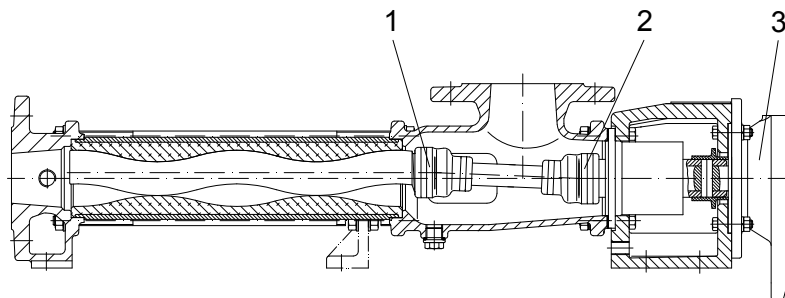

No.	Denomination	Lubricant	Lubricant change in operating hours	Fill volume
1	Pin joint	seepex special grease (30321)	10000 h	32 cm <sup>3</sup>
2	Pin joint	seepex special grease (30321)	10000 h	32 cm <sup>3</sup>
3	Drive	Refer to manufacturer's documentation (chapter 13.1)		
Rotor/stator		Conveying medium	---	---
Shaft seal		Conveying medium	---	---

7.2.1 Joint grease

<b>NOTICE</b>
<p><b>Other grease types.</b> Malfunction and/or irreparable damage to the joints or the pump.</p> <ul style="list-style-type: none"> <li>➤ Exclusively use seepex special grease.</li> </ul>

## 7.3 Inspection

Component	Interval	Action
Joints	Every 10,000 operating hours	Renew joint grease
Shaft seal	Every week	Visual check for leaks
Drive unit	Every 3000 operating hours, at least every 6 months	Comply with manufacturer's documentation

7.1 Preventive measures



The maintenance personnel must have these operating instructions, follow them and also require corresponding qualifications.

- No liability will be accepted in the event of violation.

	<b>! DANGER</b>	
	<p><b>Dangerous voltage.</b> Death or serious injury can occur.</p> <ul style="list-style-type: none"> <li>➤ Observe safety regulations.</li> <li>➤ Disconnect the pump from all sources of energy.</li> <li>➤ Prevent electrical connections from being switched on again.</li> </ul>	

7.1.1 Pump down-time

<b>NOTICE</b>
<p><b>Pump down-time.</b> Production failure due to wear.</p> <ul style="list-style-type: none"> <li>➤ Acquisition of a set of wearing parts and a set of gaskets.</li> </ul>

7.2 Lubrication

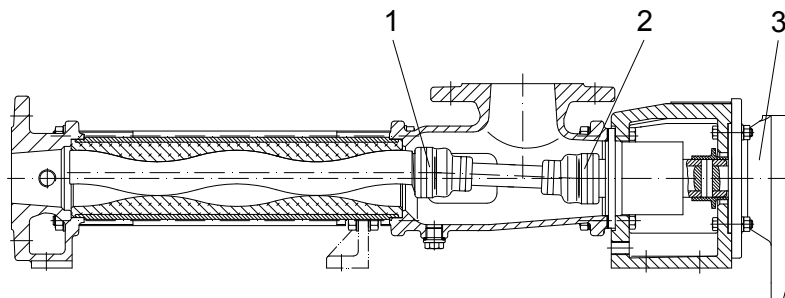

No.	Denomination	Lubricant	Lubricant change in operating hours	Fill volume
1	Pin joint	seepex special grease (30321)	10000 h	89 cm <sup>3</sup>
2	Pin joint	seepex special grease (30321)	10000 h	89 cm <sup>3</sup>
3	Drive	Refer to manufacturer's documentation (chapter 13.1)		
Rotor/stator		Conveying medium	---	---
Shaft seal		Conveying medium	---	---

7.2.1 Joint grease

<b>NOTICE</b>
<p><b>Other grease types.</b> Malfunction and/or irreparable damage to the joints or the pump.</p> <ul style="list-style-type: none"> <li>➤ Exclusively use seepex special grease.</li> </ul>

## 7.3 Inspection

Component	Interval	Action
Joints	Every 10,000 operating hours	Renew joint grease
Shaft seal	Every week	Visual check for leaks
Drive unit	Every 3000 operating hours, at least every 6 months	Comply with manufacturer's documentation

7.1 Preventive measures



The maintenance personnel must have these operating instructions, follow them and also require corresponding qualifications.

- No liability will be accepted in the event of violation.

	<b>! DANGER</b>	
	<p><b>Dangerous voltage.</b> Death or serious injury can occur.</p> <ul style="list-style-type: none"> <li>➤ Observe safety regulations.</li> <li>➤ Disconnect the pump from all sources of energy.</li> <li>➤ Prevent electrical connections from being switched on again.</li> </ul>	

7.1.1 Pump down-time

<b>NOTICE</b>
<p><b>Pump down-time.</b> Production failure due to wear.</p> <ul style="list-style-type: none"> <li>➤ Acquisition of a set of wearing parts and a set of gaskets.</li> </ul>

7.2 Lubrication

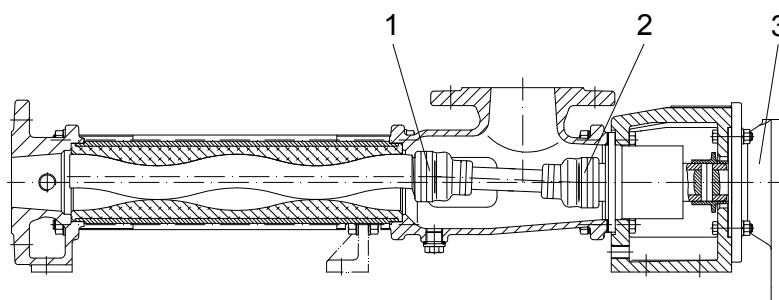

No.	Denomination	Lubricant	Lubricant change in operating hours	Fill volume
1	Pin joint	seepex special grease (30321)	10000 h	147 cm <sup>3</sup>
2	Pin joint	seepex special grease (30321)	10000 h	147 cm <sup>3</sup>
3	Drive	Refer to manufacturer's documentation (chapter 13.1)		
Rotor/stator		Conveying medium	---	---
Shaft seal		Conveying medium	---	---

7.2.1 Joint grease

<b>NOTICE</b>
<p><b>Other grease types.</b> Malfunction and/or irreparable damage to the joints or the pump.</p> <ul style="list-style-type: none"> <li>➤ Exclusively use seepex special grease.</li> </ul>

## 7.3 Inspection

Component	Interval	Action
Joints	Every 10,000 operating hours	Renew joint grease
Shaft seal	Every week	Visual check for leaks
Drive unit	Every 3000 operating hours, at least every 6 months	Comply with manufacturer's documentation

7.1 Preventive measures



The maintenance personnel must have these operating instructions, follow them and also require corresponding qualifications.

- No liability will be accepted in the event of violation.

	<b>DANGER</b>	
	<p><b>Dangerous voltage.</b> Death or serious injury can occur.</p> <ul style="list-style-type: none"> <li>➤ Observe safety regulations.</li> <li>➤ Disconnect the pump from all sources of energy.</li> <li>➤ Prevent electrical connections from being switched on again.</li> </ul>	

7.1.1 Pump down-time

<p><b>NOTICE</b></p>
<p><b>Pump down-time.</b> Production failure due to wear.</p> <ul style="list-style-type: none"> <li>➤ Acquisition of a set of wearing parts and a set of gaskets.</li> </ul>

7.2 Lubrication

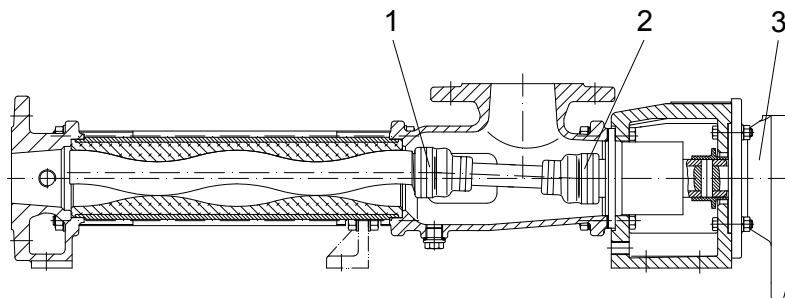

No.	Denomination	Lubricant	Lubricant change in operating hours	Fill volume
1	Pin joint	seepex special grease (30321)	10000 h	335.0 cm <sup>3</sup>
2	Pin joint	seepex special grease (30321)	10000 h	335.0 cm <sup>3</sup>
3	Drive	Refer to manufacturer's documentation (chapter 13.1)		
Rotor/stator		Conveying medium	---	---
Shaft seal		Conveying medium	---	---

7.2.1 Joint grease

<p><b>NOTICE</b></p>
<p><b>Other grease types.</b> Malfunction and/or irreparable damage to the joints or the pump.</p> <ul style="list-style-type: none"> <li>➤ Exclusively use seepex special grease.</li> </ul>

## 7.3 Inspection

Component	Interval	Action
Joints	Every 10,000 operating hours	Renew joint grease
Shaft seal	Every week	Visual check for leaks
Drive unit	Every 3000 operating hours, at least every 6 months	Comply with manufacturer's documentation

7.1 Preventive measures



The maintenance personnel must have these operating instructions, follow them and also require corresponding qualifications.

- No liability will be accepted in the event of violation.

	<b>! DANGER</b>	
	<p><b>Dangerous voltage.</b> Death or serious injury can occur.</p> <ul style="list-style-type: none"> <li>➤ Observe safety regulations.</li> <li>➤ Disconnect the pump from all sources of energy.</li> <li>➤ Prevent electrical connections from being switched on again.</li> </ul>	

7.1.1 Pump down-time

<b>NOTICE</b>
<p><b>Pump down-time.</b> Production failure due to wear.</p> <ul style="list-style-type: none"> <li>➤ Acquisition of a set of wearing parts and a set of gaskets.</li> </ul>

7.2 Lubrication

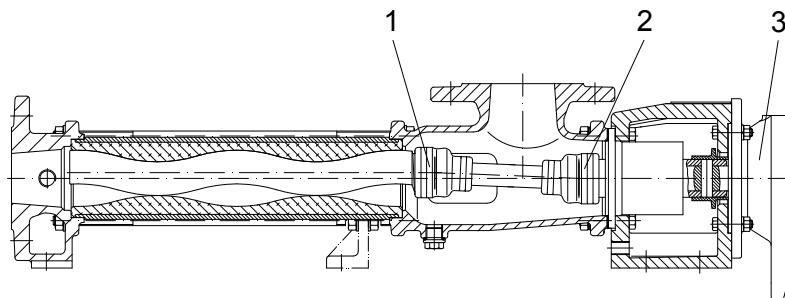

No.	Denomination	Lubricant	Lubricant change in operating hours	Fill volume
1	Pin joint	seepex special grease (30321)	10000 h	916 cm <sup>3</sup>
2	Pin joint	seepex special grease (30321)	10000 h	916 cm <sup>3</sup>
3	Drive	Refer to manufacturer's documentation (chapter 13.1)		
Rotor/stator		Conveying medium	---	---
Shaft seal		Conveying medium	---	---

7.2.1 Joint grease

<b>NOTICE</b>
<p><b>Other grease types.</b> Malfunction and/or irreparable damage to the joints or the pump.</p> <ul style="list-style-type: none"> <li>➤ Exclusively use seepex special grease.</li> </ul>

## 7.3 Inspection

Component	Interval	Action
Joints	Every 10,000 operating hours	Renew joint grease
Shaft seal	Every week	Visual check for leaks
Drive unit	Every 3000 operating hours, at least every 6 months	Comply with manufacturer's documentation

7.1 Preventive measures



The maintenance personnel must have these operating instructions, follow them and also require corresponding qualifications.

- No liability will be accepted in the event of violation.

	<b>! DANGER</b>	
	<p><b>Dangerous voltage.</b> Death or serious injury can occur.</p> <ul style="list-style-type: none"> <li>➤ Observe safety regulations.</li> <li>➤ Disconnect the pump from all sources of energy.</li> <li>➤ Prevent electrical connections from being switched on again.</li> </ul>	

7.1.1 Pump down-time

<b>NOTICE</b>
<p><b>Pump down-time.</b> Production failure due to wear.</p> <ul style="list-style-type: none"> <li>➤ Acquisition of a set of wearing parts and a set of gaskets.</li> </ul>

7.2 Lubrication

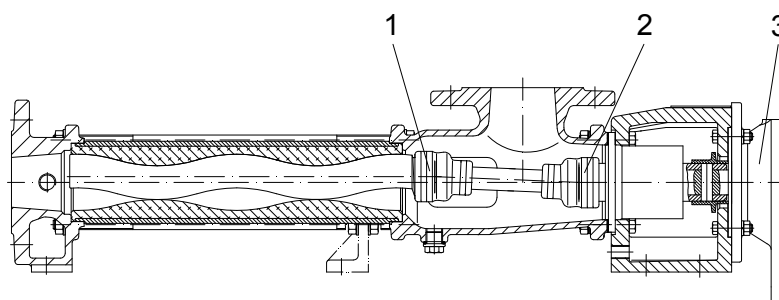

No.	Denomination	Lubricant	Lubricant change in operating hours	Fill volume
1	Pin joint	seepex special grease (10325)	10000 h	7 cm <sup>3</sup>
2	Pin joint	seepex special grease (10325)	10000 h	7 cm <sup>3</sup>
3	Drive	Refer to manufacturer's documentation (chapter 13.1)		
Rotor/stator		Conveying medium	---	---
Shaft seal		Conveying medium	---	---

7.2.1 Joint grease

<b>NOTICE</b>
<p><b>Other grease types.</b> Malfunction and/or irreparable damage to the joints or the pump.</p> <ul style="list-style-type: none"> <li>➤ Exclusively use seepex special grease.</li> </ul>

## 7.3 Inspection

Component	Interval	Action
Joints	Every 10,000 operating hours	Renew joint grease
Shaft seal	Every week	Visual check for leaks
Drive unit	Every 3000 operating hours, at least every 6 months	Comply with manufacturer's documentation

7.1 Preventive measures



The maintenance personnel must have these operating instructions, follow them and also require corresponding qualifications.

- No liability will be accepted in the event of violation.

	<b>! DANGER</b>	
	<p><b>Dangerous voltage.</b> Death or serious injury can occur.</p> <ul style="list-style-type: none"> <li>➤ Observe safety regulations.</li> <li>➤ Disconnect the pump from all sources of energy.</li> <li>➤ Prevent electrical connections from being switched on again.</li> </ul>	

7.1.1 Pump down-time

<b>NOTICE</b>
<p><b>Pump down-time.</b> Production failure due to wear.</p> <ul style="list-style-type: none"> <li>➤ Acquisition of a set of wearing parts and a set of gaskets.</li> </ul>

7.2 Lubrication

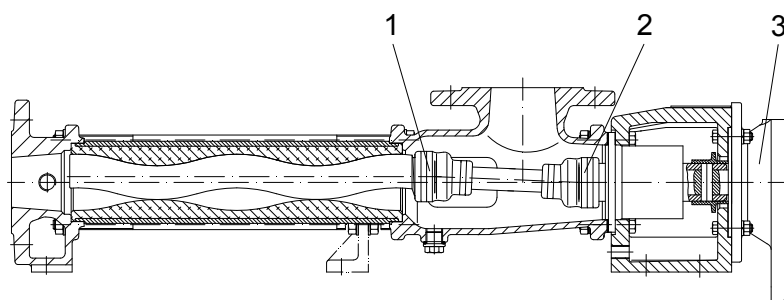

No.	Denomination	Lubricant	Lubricant change in operating hours	Fill volume
1	Pin joint	seepex special grease (10325)	10000 h	14 cm <sup>3</sup>
2	Pin joint	seepex special grease (10325)	10000 h	14 cm <sup>3</sup>
3	Drive	Refer to manufacturer's documentation (chapter 13.1)		
Rotor/stator		Conveying medium	---	---
Shaft seal		Conveying medium	---	---

7.2.1 Joint grease

<b>NOTICE</b>
<p><b>Other grease types.</b> Malfunction and/or irreparable damage to the joints or the pump.</p> <ul style="list-style-type: none"> <li>➤ Exclusively use seepex special grease.</li> </ul>

## 7.3 Inspection

Component	Interval	Action
Joints	Every 10,000 operating hours	Renew joint grease
Shaft seal	Every week	Visual check for leaks
Drive unit	Every 3000 operating hours, at least every 6 months	Comply with manufacturer's documentation

7.1 Preventive measures



The maintenance personnel must have these operating instructions, follow them and also require corresponding qualifications.

- No liability will be accepted in the event of violation.

	<b>! DANGER</b>	
	<p><b>Dangerous voltage.</b> Death or serious injury can occur.</p> <ul style="list-style-type: none"> <li>➤ Observe safety regulations.</li> <li>➤ Disconnect the pump from all sources of energy.</li> <li>➤ Prevent electrical connections from being switched on again.</li> </ul>	

7.1.1 Pump down-time

<b>NOTICE</b>
<p><b>Pump down-time.</b> Production failure due to wear.</p> <ul style="list-style-type: none"> <li>➤ Acquisition of a set of wearing parts and a set of gaskets.</li> </ul>

7.2 Lubrication

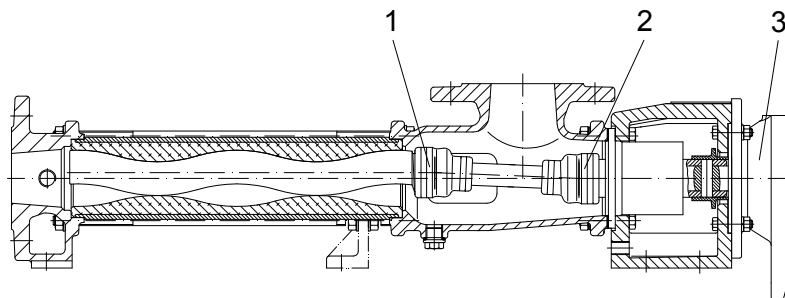

No.	Denomination	Lubricant	Lubricant change in operating hours	Fill volume
1	Pin joint	seepex special grease (10325)	10000 h	19 cm <sup>3</sup>
2	Pin joint	seepex special grease (10325)	10000 h	19 cm <sup>3</sup>
3	Drive	Refer to manufacturer's documentation (chapter 13.1)		
Rotor/stator		Conveying medium	---	---
Shaft seal		Conveying medium	---	---

7.2.1 Joint grease

<b>NOTICE</b>
<p><b>Other grease types.</b> Malfunction and/or irreparable damage to the joints or the pump.</p> <ul style="list-style-type: none"> <li>➤ Exclusively use seepex special grease.</li> </ul>

## 7.3 Inspection

Component	Interval	Action
Joints	Every 10,000 operating hours	Renew joint grease
Shaft seal	Every week	Visual check for leaks
Drive unit	Every 3000 operating hours, at least every 6 months	Comply with manufacturer's documentation

7.1 Preventive measures



The maintenance personnel must have these operating instructions, follow them and also require corresponding qualifications.

- No liability will be accepted in the event of violation.

	<b>! DANGER</b>	
	<p><b>Dangerous voltage.</b> Death or serious injury can occur.</p> <ul style="list-style-type: none"> <li>➤ Observe safety regulations.</li> <li>➤ Disconnect the pump from all sources of energy.</li> <li>➤ Prevent electrical connections from being switched on again.</li> </ul>	

7.1.1 Pump down-time

<b>NOTICE</b>
<p><b>Pump down-time.</b> Production failure due to wear.</p> <ul style="list-style-type: none"> <li>➤ Acquisition of a set of wearing parts and a set of gaskets.</li> </ul>

7.2 Lubrication

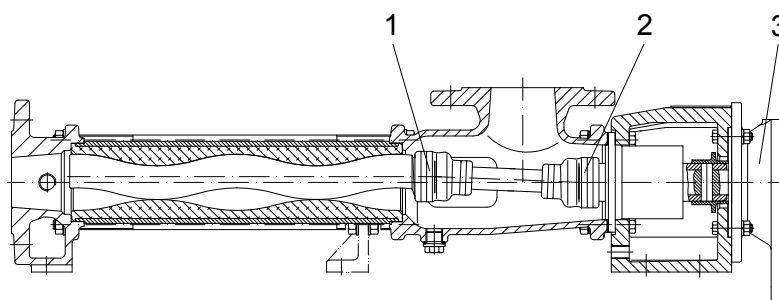

No.	Denomination	Lubricant	Lubricant change in operating hours	Fill volume
1	Pin joint	seepex special grease (10325)	10000 h	32 cm <sup>3</sup>
2	Pin joint	seepex special grease (10325)	10000 h	32 cm <sup>3</sup>
3	Drive	Refer to manufacturer's documentation (chapter 13.1)		
Rotor/stator		Conveying medium	---	---
Shaft seal		Conveying medium	---	---

7.2.1 Joint grease

<b>NOTICE</b>
<p><b>Other grease types.</b> Malfunction and/or irreparable damage to the joints or the pump.</p> <ul style="list-style-type: none"> <li>➤ Exclusively use seepex special grease.</li> </ul>

## 7.3 Inspection

Component	Interval	Action
Joints	Every 10,000 operating hours	Renew joint grease
Shaft seal	Every week	Visual check for leaks
Drive unit	Every 3000 operating hours, at least every 6 months	Comply with manufacturer's documentation

7.1 Preventive measures



The maintenance personnel must have these operating instructions, follow them and also require corresponding qualifications.

- No liability will be accepted in the event of violation.

	<b>! DANGER</b>	
	<p><b>Dangerous voltage.</b> Death or serious injury can occur.</p> <ul style="list-style-type: none"> <li>➤ Observe safety regulations.</li> <li>➤ Disconnect the pump from all sources of energy.</li> <li>➤ Prevent electrical connections from being switched on again.</li> </ul>	

7.1.1 Pump down-time

<b>NOTICE</b>
<p><b>Pump down-time.</b> Production failure due to wear.</p> <ul style="list-style-type: none"> <li>➤ Acquisition of a set of wearing parts and a set of gaskets.</li> </ul>

7.2 Lubrication

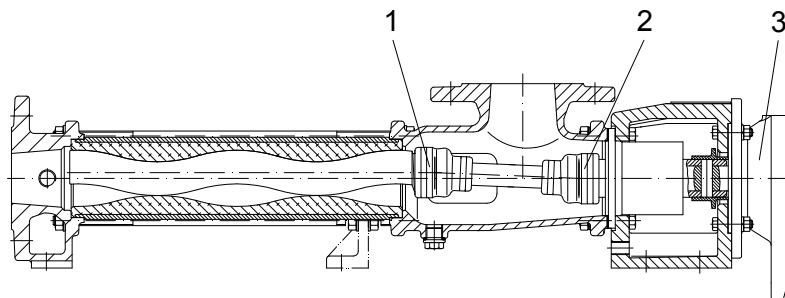

No.	Denomination	Lubricant	Lubricant change in operating hours	Fill volume
1	Pin joint	seepex special grease (10325)	10000 h	50 cm <sup>3</sup>
2	Pin joint	seepex special grease (10325)	10000 h	50 cm <sup>3</sup>
3	Drive	Refer to manufacturer's documentation (chapter 13.1)		
Rotor/stator		Conveying medium	---	---
Shaft seal		Conveying medium	---	---

7.2.1 Joint grease

<b>NOTICE</b>
<p><b>Other grease types.</b> Malfunction and/or irreparable damage to the joints or the pump.</p> <ul style="list-style-type: none"> <li>➤ Exclusively use seepex special grease.</li> </ul>

## 7.3 Inspection

Component	Interval	Action
Joints	Every 10,000 operating hours	Renew joint grease
Shaft seal	Every week	Visual check for leaks
Drive unit	Every 3000 operating hours, at least every 6 months	Comply with manufacturer's documentation

7.1 Preventive measures



The maintenance personnel must have these operating instructions, follow them and also require corresponding qualifications.

- No liability will be accepted in the event of violation.

	<b>! DANGER</b>	
	<p><b>Dangerous voltage.</b> Death or serious injury can occur.</p> <ul style="list-style-type: none"> <li>➤ Observe safety regulations.</li> <li>➤ Disconnect the pump from all sources of energy.</li> <li>➤ Prevent electrical connections from being switched on again.</li> </ul>	

7.1.1 Pump down-time

<b>NOTICE</b>
<p><b>Pump down-time.</b> Production failure due to wear.</p> <ul style="list-style-type: none"> <li>➤ Acquisition of a set of wearing parts and a set of gaskets.</li> </ul>

7.2 Lubrication

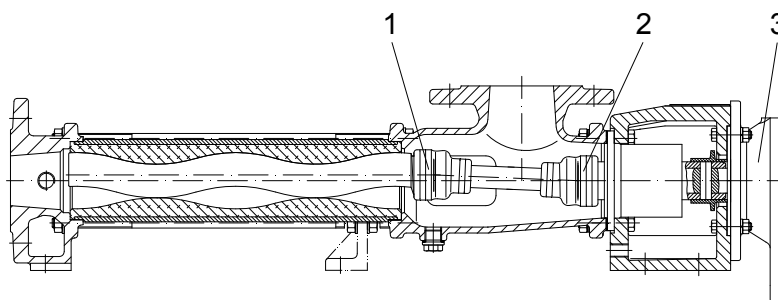

No.	Denomination	Lubricant	Lubricant change in operating hours	Fill volume
1	Pin joint	seepex special grease (10325)	10000 h	64 cm <sup>3</sup>
2	Pin joint	seepex special grease (10325)	10000 h	64 cm <sup>3</sup>
3	Drive	Refer to manufacturer's documentation (chapter 13.1)		
Rotor/stator		Conveying medium	---	---
Shaft seal		Conveying medium	---	---

7.2.1 Joint grease

<b>NOTICE</b>
<p><b>Other grease types.</b> Malfunction and/or irreparable damage to the joints or the pump.</p> <ul style="list-style-type: none"> <li>➤ Exclusively use seepex special grease.</li> </ul>

## 7.3 Inspection

Component	Interval	Action
Joints	Every 10,000 operating hours	Renew joint grease
Shaft seal	Every week	Visual check for leaks
Drive unit	Every 3000 operating hours, at least every 6 months	Comply with manufacturer's documentation

7.1 Preventive measures



The maintenance personnel must have these operating instructions, follow them and also require corresponding qualifications.

- No liability will be accepted in the event of violation.

	<b>DANGER</b>	
	<p><b>Dangerous voltage.</b> Death or serious injury can occur.</p> <ul style="list-style-type: none"> <li>➤ Observe safety regulations.</li> <li>➤ Disconnect the pump from all sources of energy.</li> <li>➤ Prevent electrical connections from being switched on again.</li> </ul>	

7.1.1 Pump down-time

<b>NOTICE</b>
<p><b>Pump down-time.</b> Production failure due to wear.</p> <ul style="list-style-type: none"> <li>➤ Acquisition of a set of wearing parts and a set of gaskets.</li> </ul>

7.2 Lubrication

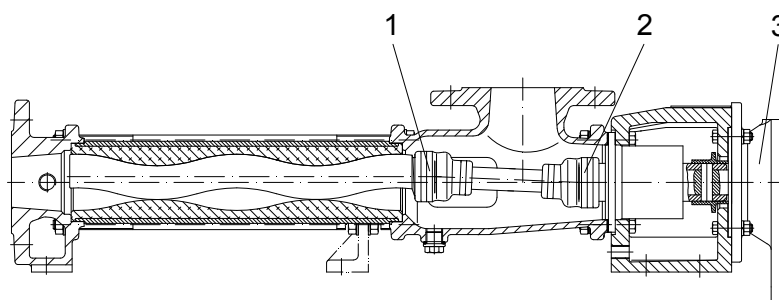

No.	Denomination	Lubricant	Lubricant change in operating hours	Fill volume
1	Pin joint	seepex special grease (10325)	10000 h	89 cm <sup>3</sup>
2	Pin joint	seepex special grease (10325)	10000 h	89 cm <sup>3</sup>
3	Drive	Refer to manufacturer's documentation (chapter 13.1)		
Rotor/stator		Conveying medium	---	---
Shaft seal		Conveying medium	---	---

7.2.1 Joint grease

<b>NOTICE</b>
<p><b>Other grease types.</b> Malfunction and/or irreparable damage to the joints or the pump.</p> <ul style="list-style-type: none"> <li>➤ Exclusively use seepex special grease.</li> </ul>

## 7.3 Inspection

Component	Interval	Action
Joints	Every 10,000 operating hours	Renew joint grease
Shaft seal	Every week	Visual check for leaks
Drive unit	Every 3000 operating hours, at least every 6 months	Comply with manufacturer's documentation

7.1 Preventive measures



The maintenance personnel must have these operating instructions, follow them and also require corresponding qualifications.

- No liability will be accepted in the event of violation.

	<b>! DANGER</b>	
	<p><b>Dangerous voltage.</b> Death or serious injury can occur.</p> <ul style="list-style-type: none"> <li>➤ Observe safety regulations.</li> <li>➤ Disconnect the pump from all sources of energy.</li> <li>➤ Prevent electrical connections from being switched on again.</li> </ul>	

7.1.1 Pump down-time

<b>NOTICE</b>
<p><b>Pump down-time.</b> Production failure due to wear.</p> <ul style="list-style-type: none"> <li>➤ Acquisition of a set of wearing parts and a set of gaskets.</li> </ul>

7.2 Lubrication

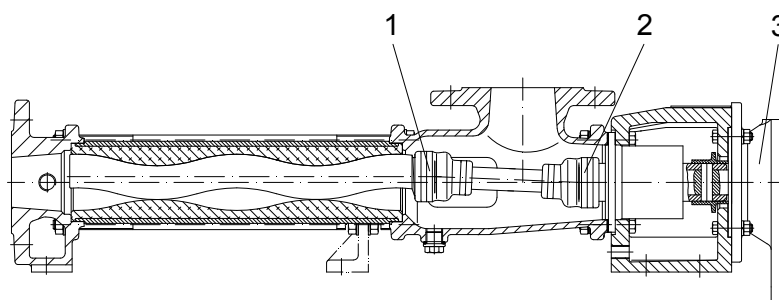

No.	Denomination	Lubricant	Lubricant change in operating hours	Fill volume
1	Pin joint	seepex special grease (10325)	10000 h	147 cm <sup>3</sup>
2	Pin joint	seepex special grease (10325)	10000 h	147 cm <sup>3</sup>
3	Drive	Refer to manufacturer's documentation (chapter 13.1)		
Rotor/stator		Conveying medium	---	---
Shaft seal		Conveying medium	---	---

7.2.1 Joint grease

<b>NOTICE</b>
<p><b>Other grease types.</b> Malfunction and/or irreparable damage to the joints or the pump.</p> <ul style="list-style-type: none"> <li>➤ Exclusively use seepex special grease.</li> </ul>

## 7.3 Inspection

Component	Interval	Action
Joints	Every 10,000 operating hours	Renew joint grease
Shaft seal	Every week	Visual check for leaks
Drive unit	Every 3000 operating hours, at least every 6 months	Comply with manufacturer's documentation

7.1 Preventive measures



The maintenance personnel must have these operating instructions, follow them and also require corresponding qualifications.

- No liability will be accepted in the event of violation.

	<b>! DANGER</b>	
	<p><b>Dangerous voltage.</b> Death or serious injury can occur.</p> <ul style="list-style-type: none"> <li>➤ Observe safety regulations.</li> <li>➤ Disconnect the pump from all sources of energy.</li> <li>➤ Prevent electrical connections from being switched on again.</li> </ul>	

7.1.1 Pump down-time

<b>NOTICE</b>
<p><b>Pump down-time.</b> Production failure due to wear.</p> <ul style="list-style-type: none"> <li>➤ Acquisition of a set of wearing parts and a set of gaskets.</li> </ul>

7.2 Lubrication

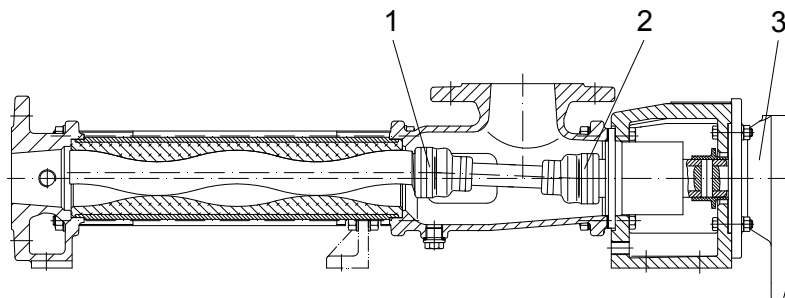

No.	Denomination	Lubricant	Lubricant change in operating hours	Fill volume
1	Pin joint	seepex special grease (10325)	10000 h	335 cm <sup>3</sup>
2	Pin joint	seepex special grease (10325)	10000 h	335 cm <sup>3</sup>
3	Drive	Refer to manufacturer's documentation (chapter 13.1)		
Rotor/stator		Conveying medium	---	---
Shaft seal		Conveying medium	---	---

7.2.1 Joint grease

<b>NOTICE</b>
<p><b>Other grease types.</b> Malfunction and/or irreparable damage to the joints or the pump.</p> <ul style="list-style-type: none"> <li>➤ Exclusively use seepex special grease.</li> </ul>

## 7.3 Inspection

Component	Interval	Action
Joints	Every 10,000 operating hours	Renew joint grease
Shaft seal	Every week	Visual check for leaks
Drive unit	Every 3000 operating hours, at least every 6 months	Comply with manufacturer's documentation

7.1 Preventive measures



The maintenance personnel must have these operating instructions, follow them and also require corresponding qualifications.

- No liability will be accepted in the event of violation.

	<b>! DANGER</b>	
	<p><b>Dangerous voltage.</b> Death or serious injury can occur.</p> <ul style="list-style-type: none"> <li>➤ Observe safety regulations.</li> <li>➤ Disconnect the pump from all sources of energy.</li> <li>➤ Prevent electrical connections from being switched on again.</li> </ul>	

7.1.1 Pump down-time

<b>NOTICE</b>
<p><b>Pump down-time.</b> Production failure due to wear.</p> <ul style="list-style-type: none"> <li>➤ Acquisition of a set of wearing parts and a set of gaskets.</li> </ul>

7.2 Lubrication

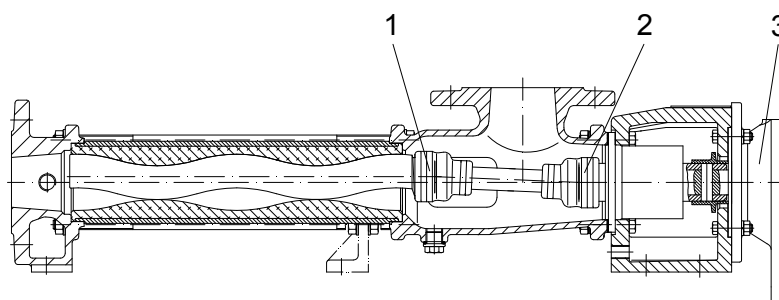

No.	Denomination	Lubricant	Lubricant change in operating hours	Fill volume
1	Pin joint	seepex special grease (10325)	10000 h	916 cm <sup>3</sup>
2	Pin joint	seepex special grease (10325)	10000 h	916 cm <sup>3</sup>
3	Drive	Refer to manufacturer's documentation (chapter 13.1)		
Rotor/stator		Conveying medium	---	---
Shaft seal		Conveying medium	---	---

7.2.1 Joint grease

<b>NOTICE</b>
<p><b>Other grease types.</b> Malfunction and/or irreparable damage to the joints or the pump.</p> <ul style="list-style-type: none"> <li>➤ Exclusively use seepex special grease.</li> </ul>

## 7.3 Inspection

Component	Interval	Action
Joints	Every 10,000 operating hours	Renew joint grease
Shaft seal	Every week	Visual check for leaks
Drive unit	Every 3000 operating hours, at least every 6 months	Comply with manufacturer's documentation

7.1 Preventive measures



The maintenance personnel must have these operating instructions, follow them and also require corresponding qualifications.

- No liability will be accepted in the event of violation.

	<b>! DANGER</b>	
	<p><b>Dangerous voltage.</b> Death or serious injury can occur.</p> <ul style="list-style-type: none"> <li>➤ Observe safety regulations.</li> <li>➤ Disconnect the pump from all sources of energy.</li> <li>➤ Prevent electrical connections from being switched on again.</li> </ul>	

7.1.1 Pump down-time

<b>NOTICE</b>
<p><b>Pump down-time.</b> Production failure due to wear.</p> <ul style="list-style-type: none"> <li>➤ Acquisition of a set of wearing parts and a set of gaskets.</li> </ul>

7.2 Lubrication

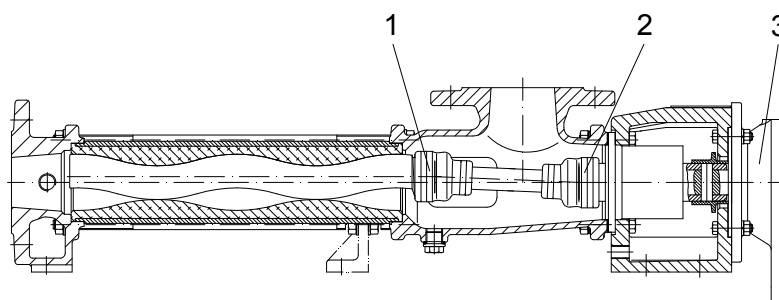

No.	Denomination	Lubricant	Lubricant change in operating hours	Fill volume
1	Pin joint	seepex special grease (30322)	10000 h	7 cm <sup>3</sup>
2	Pin joint	seepex special grease (30322)	10000 h	7 cm <sup>3</sup>
3	Drive	Refer to manufacturer's documentation (chapter 13.1)		
Rotor/stator		Conveying medium	---	---
Shaft seal		Conveying medium	---	---

7.2.1 Joint grease

<b>NOTICE</b>
<p><b>Other grease types.</b> Malfunction and/or irreparable damage to the joints or the pump.</p> <ul style="list-style-type: none"> <li>➤ Exclusively use seepex special grease.</li> </ul>

## 7.3 Inspection

Component	Interval	Action
Joints	Every 10,000 operating hours	Renew joint grease
Shaft seal	Every week	Visual check for leaks
Drive unit	Every 3000 operating hours, at least every 6 months	Comply with manufacturer's documentation

7.1 Preventive measures



The maintenance personnel must have these operating instructions, follow them and also require corresponding qualifications.

- No liability will be accepted in the event of violation.

	<b>DANGER</b>	
	<p><b>Dangerous voltage.</b> Death or serious injury can occur.</p> <ul style="list-style-type: none"> <li>➤ Observe safety regulations.</li> <li>➤ Disconnect the pump from all sources of energy.</li> <li>➤ Prevent electrical connections from being switched on again.</li> </ul>	

7.1.1 Pump down-time

<b>NOTICE</b>
<p><b>Pump down-time.</b> Production failure due to wear.</p> <ul style="list-style-type: none"> <li>➤ Acquisition of a set of wearing parts and a set of gaskets.</li> </ul>

7.2 Lubrication

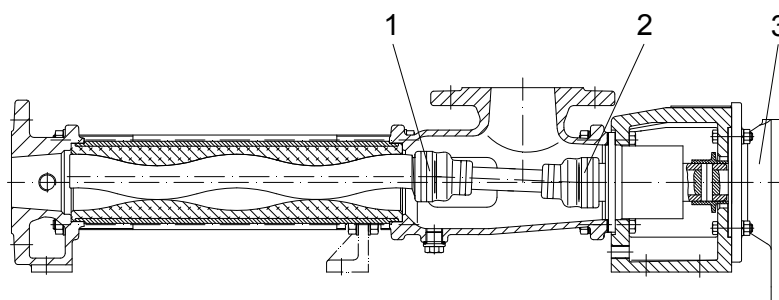

No.	Denomination	Lubricant	Lubricant change in operating hours	Fill volume
1	Pin joint	seepex special grease (30322)	10000 h	14 cm <sup>3</sup>
2	Pin joint	seepex special grease (30322)	10000 h	14 cm <sup>3</sup>
3	Drive	Refer to manufacturer's documentation (chapter 13.1)		
Rotor/stator		Conveying medium	---	---
Shaft seal		Conveying medium	---	---

7.2.1 Joint grease

<b>NOTICE</b>
<p><b>Other grease types.</b> Malfunction and/or irreparable damage to the joints or the pump.</p> <ul style="list-style-type: none"> <li>➤ Exclusively use seepex special grease.</li> </ul>

## 7.3 Inspection

Component	Interval	Action
Joints	Every 10,000 operating hours	Renew joint grease
Shaft seal	Every week	Visual check for leaks
Drive unit	Every 3000 operating hours, at least every 6 months	Comply with manufacturer's documentation

7.1 Preventive measures



The maintenance personnel must have these operating instructions, follow them and also require corresponding qualifications.

- No liability will be accepted in the event of violation.

	<b>! DANGER</b>	
	<p><b>Dangerous voltage.</b> Death or serious injury can occur.</p> <ul style="list-style-type: none"> <li>➤ Observe safety regulations.</li> <li>➤ Disconnect the pump from all sources of energy.</li> <li>➤ Prevent electrical connections from being switched on again.</li> </ul>	

7.1.1 Pump down-time

<b>NOTICE</b>
<p><b>Pump down-time.</b> Production failure due to wear.</p> <ul style="list-style-type: none"> <li>➤ Acquisition of a set of wearing parts and a set of gaskets.</li> </ul>

7.2 Lubrication

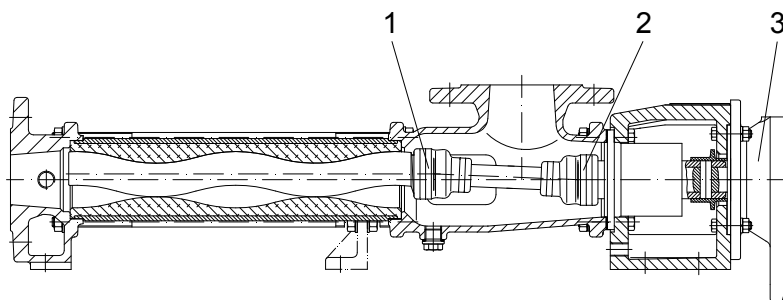

No.	Denomination	Lubricant	Lubricant change in operating hours	Fill volume
1	Pin joint	seepex special grease (30322)	10000 h	19 cm <sup>3</sup>
2	Pin joint	seepex special grease (30322)	10000 h	19 cm <sup>3</sup>
3	Drive	Refer to manufacturer's documentation (chapter 13.1)		
Rotor/stator		Conveying medium	---	---
Shaft seal		Conveying medium	---	---

7.2.1 Joint grease

<b>NOTICE</b>
<p><b>Other grease types.</b> Malfunction and/or irreparable damage to the joints or the pump.</p> <ul style="list-style-type: none"> <li>➤ Exclusively use seepex special grease.</li> </ul>

## 7.3 Inspection

Component	Interval	Action
Joints	Every 10,000 operating hours	Renew joint grease
Shaft seal	Every week	Visual check for leaks
Drive unit	Every 3000 operating hours, at least every 6 months	Comply with manufacturer's documentation

7.1 Preventive measures



The maintenance personnel must have these operating instructions, follow them and also require corresponding qualifications.

- No liability will be accepted in the event of violation.

	<b>! DANGER</b>	
	<p><b>Dangerous voltage.</b> Death or serious injury can occur.</p> <ul style="list-style-type: none"> <li>➤ Observe safety regulations.</li> <li>➤ Disconnect the pump from all sources of energy.</li> <li>➤ Prevent electrical connections from being switched on again.</li> </ul>	

7.1.1 Pump down-time

<b>NOTICE</b>
<p><b>Pump down-time.</b> Production failure due to wear.</p> <ul style="list-style-type: none"> <li>➤ Acquisition of a set of wearing parts and a set of gaskets.</li> </ul>

7.2 Lubrication

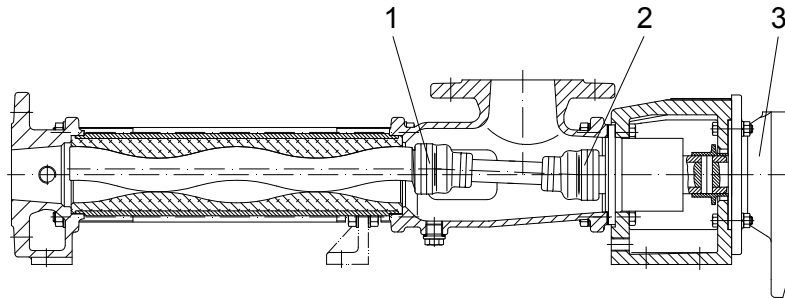

No.	Denomination	Lubricant	Lubricant change in operating hours	Fill volume
1	Pin joint	seepex special grease (30322)	10000 h	32 cm <sup>3</sup>
2	Pin joint	seepex special grease (30322)	10000 h	32 cm <sup>3</sup>
3	Drive	Refer to manufacturer's documentation (chapter 13.1)		
Rotor/stator		Conveying medium	---	---
Shaft seal		Conveying medium	---	---

7.2.1 Joint grease

<b>NOTICE</b>
<p><b>Other grease types.</b> Malfunction and/or irreparable damage to the joints or the pump.</p> <ul style="list-style-type: none"> <li>➤ Exclusively use seepex special grease.</li> </ul>

## 7.3 Inspection

Component	Interval	Action
Joints	Every 10,000 operating hours	Renew joint grease
Shaft seal	Every week	Visual check for leaks
Drive unit	Every 3000 operating hours, at least every 6 months	Comply with manufacturer's documentation

7.1 Preventive measures



The maintenance personnel must have these operating instructions, follow them and also require corresponding qualifications.

- No liability will be accepted in the event of violation.

	<b>! DANGER</b>	
	<p><b>Dangerous voltage.</b> Death or serious injury can occur.</p> <ul style="list-style-type: none"> <li>➤ Observe safety regulations.</li> <li>➤ Disconnect the pump from all sources of energy.</li> <li>➤ Prevent electrical connections from being switched on again.</li> </ul>	

7.1.1 Pump down-time

<b>NOTICE</b>
<p><b>Pump down-time.</b> Production failure due to wear.</p> <ul style="list-style-type: none"> <li>➤ Acquisition of a set of wearing parts and a set of gaskets.</li> </ul>

7.2 Lubrication

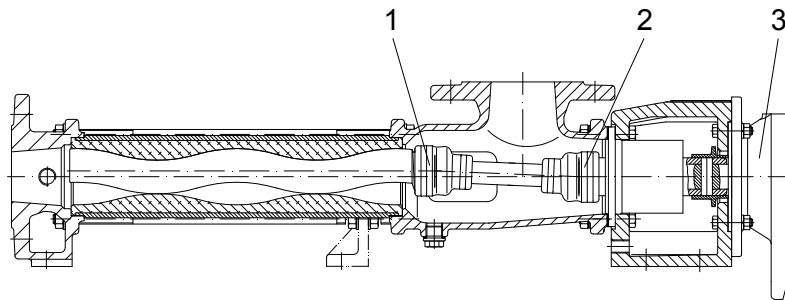

No.	Denomination	Lubricant	Lubricant change in operating hours	Fill volume
1	Pin joint	seepex special grease (30322)	10000 h	50 cm <sup>3</sup>
2	Pin joint	seepex special grease (30322)	10000 h	50 cm <sup>3</sup>
3	Drive	Refer to manufacturer's documentation (chapter 13.1)		
Rotor/stator		Conveying medium	---	---
Shaft seal		Conveying medium	---	---

7.2.1 Joint grease

<b>NOTICE</b>
<p><b>Other grease types.</b> Malfunction and/or irreparable damage to the joints or the pump.</p> <ul style="list-style-type: none"> <li>➤ Exclusively use seepex special grease.</li> </ul>

## 7.3 Inspection

Component	Interval	Action
Joints	Every 10,000 operating hours	Renew joint grease
Shaft seal	Every week	Visual check for leaks
Drive unit	Every 3000 operating hours, at least every 6 months	Comply with manufacturer's documentation

7.1 Preventive measures



The maintenance personnel must have these operating instructions, follow them and also require corresponding qualifications.

- No liability will be accepted in the event of violation.

	<b>! DANGER</b>	
	<p><b>Dangerous voltage.</b> Death or serious injury can occur.</p> <ul style="list-style-type: none"> <li>➤ Observe safety regulations.</li> <li>➤ Disconnect the pump from all sources of energy.</li> <li>➤ Prevent electrical connections from being switched on again.</li> </ul>	

7.1.1 Pump down-time

<b>NOTICE</b>
<p><b>Pump down-time.</b> Production failure due to wear.</p> <ul style="list-style-type: none"> <li>➤ Acquisition of a set of wearing parts and a set of gaskets.</li> </ul>

7.2 Lubrication

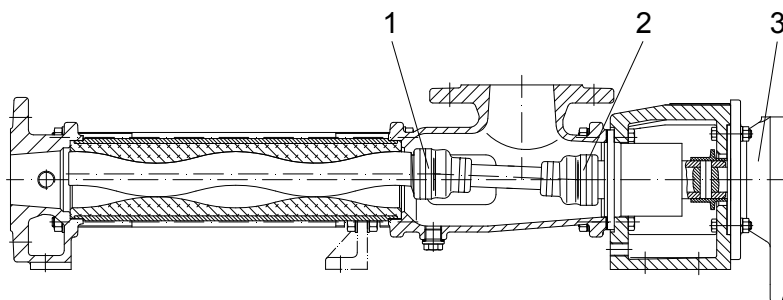

No.	Denomination	Lubricant	Lubricant change in operating hours	Fill volume
1	Pin joint	seepex special grease (30322)	10000 h	64 cm <sup>3</sup>
2	Pin joint	seepex special grease (30322)	10000 h	64 cm <sup>3</sup>
3	Drive	Refer to manufacturer's documentation (chapter 13.1)		
Rotor/stator		Conveying medium	---	---
Shaft seal		Conveying medium	---	---

7.2.1 Joint grease

<b>NOTICE</b>
<p><b>Other grease types.</b> Malfunction and/or irreparable damage to the joints or the pump.</p> <ul style="list-style-type: none"> <li>➤ Exclusively use seepex special grease.</li> </ul>

## 7.3 Inspection

Component	Interval	Action
Joints	Every 10,000 operating hours	Renew joint grease
Shaft seal	Every week	Visual check for leaks
Drive unit	Every 3000 operating hours, at least every 6 months	Comply with manufacturer's documentation

7.1 Preventive measures



The maintenance personnel must have these operating instructions, follow them and also require corresponding qualifications.

- No liability will be accepted in the event of violation.

	⚠ DANGER	
	<p><b>Dangerous voltage</b> Death or serious injury can occur</p> <ul style="list-style-type: none"> <li>➤ Observe safety regulations</li> <li>➤ Disconnect the pump from all sources of energy</li> </ul>	

7.1.1 Pump down-time

NOTICE
<p><b>Pump down-time.</b> Production failure due to wear.</p> <ul style="list-style-type: none"> <li>➤ Acquisition of a set of wearing parts and a set of gaskets.</li> </ul>

7.2 Lubrication

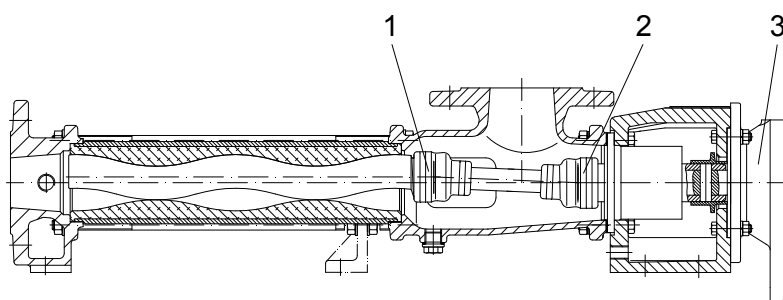

No.	Denomination	Lubricant	Lubricant change in operating hours	Fill volume
1	Pin joint	seepex special grease (30322)	10000 h	89 cm <sup>3</sup>
2	Pin joint	seepex special grease (30322)	10000 h	89 cm <sup>3</sup>
3	Drive	Refer to manufacturer's documentation (chapter 13.1)		
Rotor/stator		Conveying medium	---	---
Shaft seal		Conveying medium	---	---

7.2.1 Joint grease

NOTICE
<p><b>Other grease types.</b> Malfunction and/or irreparable damage to the joints or the pump.</p> <ul style="list-style-type: none"> <li>➤ Exclusively use seepex special grease.</li> </ul>

## 7.3 Inspection

Component	Interval	Action
Joints	Every 10,000 operating hours	Renew joint grease
Shaft seal	Every week	Visual check for leaks
Drive unit	Every 3000 operating hours, at least every 6 months	Comply with manufacturer's documentation

7.1 Preventive measures



The maintenance personnel must have these operating instructions, follow them and also require corresponding qualifications.

- No liability will be accepted in the event of violation.

	<b>! DANGER</b>	
	<p><b>Dangerous voltage</b> Death or serious injury can occur</p> <ul style="list-style-type: none"> <li>➤ Observe safety regulations</li> <li>➤ Disconnect the pump from all sources of energy</li> </ul>	

7.1.1 Pump down-time

<b>NOTICE</b>
<p><b>Pump down-time.</b> Production failure due to wear.</p> <ul style="list-style-type: none"> <li>➤ Acquisition of a set of wearing parts and a set of gaskets.</li> </ul>

7.2 Lubrication

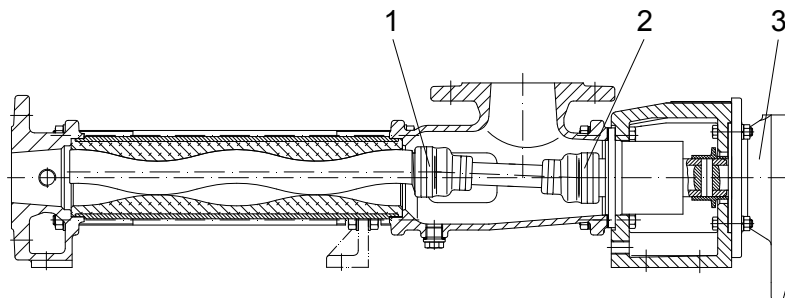

No.	Denomination	Lubricant	Lubricant change in operating hours	Fill volume
1	Pin joint	seepex special grease (30322)	10000 h	147 cm <sup>3</sup>
2	Pin joint	seepex special grease (30322)	10000 h	147 cm <sup>3</sup>
3	Drive	Refer to manufacturer's documentation (chapter 13.1)		
Rotor/stator		Conveying medium	---	---
Shaft seal		Conveying medium	---	---

7.2.1 Joint grease

<b>NOTICE</b>
<p><b>Other grease types.</b> Malfunction and/or irreparable damage to the joints or the pump.</p> <ul style="list-style-type: none"> <li>➤ Exclusively use seepex special grease.</li> </ul>

## 7.3 Inspection

Component	Interval	Action
Joints	Every 10,000 operating hours	Renew joint grease
Shaft seal	Every week	Visual check for leaks
Drive unit	Every 3000 operating hours, at least every 6 months	Comply with manufacturer's documentation

7.1 Preventive measures



The maintenance personnel must have these operating instructions, follow them and also require corresponding qualifications.

- No liability will be accepted in the event of violation.

	<b>! DANGER</b>	
	<p><b>Dangerous voltage.</b> Death or serious injury can occur.</p> <ul style="list-style-type: none"> <li>➤ Observe safety regulations.</li> <li>➤ Disconnect the pump from all sources of energy.</li> <li>➤ Prevent electrical connections from being switched on again.</li> </ul>	

7.1.1 Pump down-time

<b>NOTICE</b>
<p><b>Pump down-time.</b> Production failure due to wear.</p> <ul style="list-style-type: none"> <li>➤ Acquisition of a set of wearing parts and a set of gaskets.</li> </ul>

7.2 Lubrication

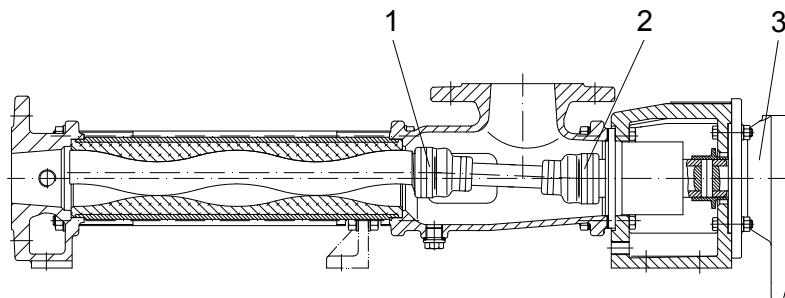

No.	Denomination	Lubricant	Lubricant change in operating hours	Fill volume
1	Pin joint	seepex special grease (30322)	10000 h	335 cm <sup>3</sup>
2	Pin joint	seepex special grease (30322)	10000 h	335 cm <sup>3</sup>
3	Drive	Refer to manufacturer's documentation (chapter 13.1)		
Rotor/stator		Conveying medium	---	---
Shaft seal		Conveying medium	---	---

7.2.1 Joint grease

<b>NOTICE</b>
<p><b>Other grease types.</b> Malfunction and/or irreparable damage to the joints or the pump.</p> <ul style="list-style-type: none"> <li>➤ Exclusively use seepex special grease.</li> </ul>

## 7.3 Inspection

Component	Interval	Action
Joints	Every 10,000 operating hours	Renew joint grease
Shaft seal	Every week	Visual check for leaks
Drive unit	Every 3000 operating hours, at least every 6 months	Comply with manufacturer's documentation

7.1 Preventive measures



The maintenance personnel must have these operating instructions, follow them and also require corresponding qualifications.

- No liability will be accepted in the event of violation.

	<b>! DANGER</b>	
	<p><b>Dangerous voltage</b> Death or serious injury can occur</p> <ul style="list-style-type: none"> <li>➤ Observe safety regulations</li> <li>➤ Disconnect the pump from all sources of energy</li> </ul>	

7.1.1 Pump down-time

<b>NOTICE</b>
<p><b>Pump down-time.</b> Production failure due to wear.</p> <ul style="list-style-type: none"> <li>➤ Acquisition of a set of wearing parts and a set of gaskets.</li> </ul>

7.2 Lubrication

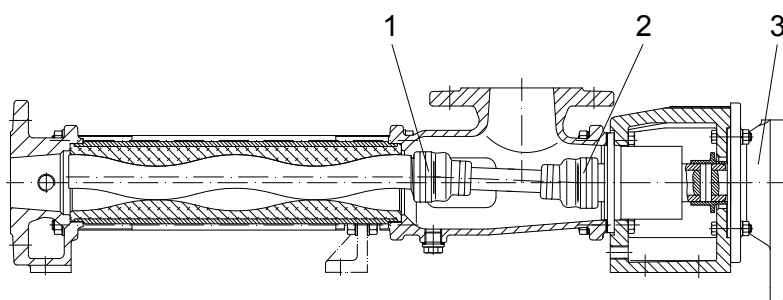

No.	Denomination	Lubricant	Lubricant change in operating hours	Fill volume
1	Pin joint	seepex special grease (30322)	10000 h	916 cm <sup>3</sup>
2	Pin joint	seepex special grease (30322)	10000 h	916 cm <sup>3</sup>
3	Drive	Refer to manufacturer's documentation (chapter 13.1)		
Rotor/stator		Conveying medium	---	---
Shaft seal		Conveying medium	---	---

7.2.1 Joint grease

<b>NOTICE</b>
<p><b>Other grease types.</b> Malfunction and/or irreparable damage to the joints or the pump.</p> <ul style="list-style-type: none"> <li>➤ Exclusively use seepex special grease.</li> </ul>

## 7.3 Inspection

Component	Interval	Action
Joints	Every 10,000 operating hours	Renew joint grease
Shaft seal	Every week	Visual check for leaks
Drive unit	Every 3000 operating hours, at least every 6 months	Comply with manufacturer's documentation

Refer to technical data (chapter 3.) for application range of the pump.



Malfunction								Causes	Rectification
Pump is not sucking	Pump pumping unevenly	Conveying capacity is not achieved	Pressure head is not reached	Pump does not start up	Pump seized / pump does not pump	Pump is loud when running	Motor gets too hot		
			X				X	Static friction between stator/rotor too great.	Apply lubricant (liquid soap) between stator and rotor.
X								Incorrect direction of rotation.	Check direction of rotation and swap over motor connections if necessary.
X	X	X			X	X		Suction pipe or shaft seal leaking.	Eliminate leaks.
X	X	X				X		Suction head too great.	Check the suction head, if necessary increase pipe cross section on suction pipe and use a larger filter, open suction-side valve fully.
X	X	X						Viscosity of conveying product too great.	Check/adapt (data sheet).
		X	X				X	Pump rotation speed incorrect.	Correct rotation speed (data sheet).
	X	X							Avoid air bubbles in the conveying product.
		X	X	X		X	X	Pressure head too great.	Check pressure head with pressure gauge, reduce pressure head by using larger pressure pipe crossed section or shortening the pressure pipe.
X	X	X			X		X	Pump running partially/ completely dry.	Check there is adequate conveying product available on the suction side. Dry running protection DRP.
						X	X	Check coupling.	If necessary, move pump in relation to drive, check wear on coupling gear, re-adjust coupling if necessary.
X		X						Rotation speed too low.	Increase rotation speed for low-viscosity media/large suction volume.

Malfunction									Causes	Rectification	
Pump is not sucking	Pump pumping unevenly	Conveying capacity is not achieved	Pressure head is not reached	Pump does not start up	Pump seized / pump does not pump	Pump is loud when running	Motor gets too hot	Premature stator wear			Shaft seal is leaky
X	X					X				Rotation speed too high.	Reduce rotation speed for high-viscosity media, risk of cavitation.
						X				Joint play too large.	Check mounting of coupling rod bushing.
X		X		X	X			X		Foreign objects in pump.	Dismantle pump, remove foreign bodies, replace defective parts.
X		X	X		X					Stator/rotor worn.	Dismantle pump and renew defective parts.
X		X			X	X				Joint parts worn.	Renew joint parts, use seepex pin joint grease.
X		X			X			X		Suction pipe blocked.	Clean the suction pipe.
X				X	X		X	X		Temperature of pumping liquid too high.	Check temperature, use an undersize rotor.
X		X		X			X		X	Gland packing too firm/worn.	Loosen packing gland or tighten. Renew unusable packing rings.
X				X	X			X		Solid content and/or grain size too great.	Reduce pump speed, install screen with permitted mesh width. Increase liquid proportion.
X				X				X	X	Sedimentation/gumming of solids when pump stationary.	Rinse through and clean the pump immediately.
X				X	X			X	X	Conveying product hardens when the temperature drops below a certain limit.	Heat the pump.
				X	X		X	X		Stator swollen and unable to withstand conveying product.	Select a suitable stator material, use an undersize rotor.
						X			X	Bearings in pump drive housing or drive unit defective.	Renew bearings.
									X	Mechanical seal defective.	Check sliprings and O-rings for wear/resistance, renew if necessary.

9.1 Pump Dismantling / Reassembly

Range: BN  
Size: 025-24 up to 300-6L

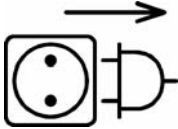

9.1.1 Prepare the pump for dismantling

	 <b>DANGER</b>	
	<p><b>Dangerous voltage.</b> Death or serious injury can occur.</p> <ul style="list-style-type: none"> <li>➤ Note safety regulations.</li> <li>➤ Disconnect pump from all sources of energy.</li> <li>➤ Secure electrical connections against restarting.</li> </ul>	

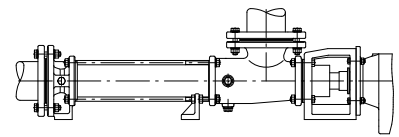
- Empty pipelines.
- Allow pipelines to cool down.
- Remove pipeline connections (suction side/pressure side).
- Note decommissioning (chapter 6.\_).

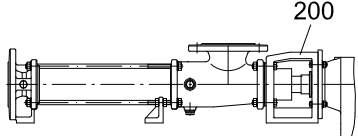

9.1.2 Dismantling

	 <b>WARNING</b>	
	<p><b>Tilting or falling pump.</b> Death or serious injury can result.</p> <ul style="list-style-type: none"> <li>➤ Attach lantern (200) to secure the pump.</li> </ul>	

9.1.2.1 Pressure branch (700) - dismantling

- Support stator (601) with base (S).

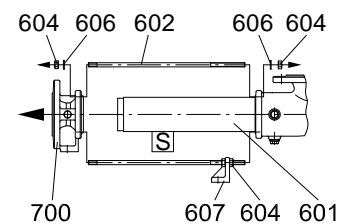

9.1.2.2 Stator (601) - dismantling

- Lift/slide splash ring (310).
- Push out plug-in shaft pin (309) horizontally.
- Turn plug-in shaft pin (309) upwards.

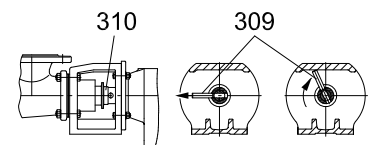

 Tool (W2/chain pipe wrench)

- Add lubricant (liquid soap) to the opening on pressure branch side between the rotor (600) and the stator (601).
- Turn the stator in the "right" rotating direction.
- Dispense lubricant (GM) on the stator internal surface in order to reduce friction between the rotor and stator.
- Support the rotor (600) with base (S).

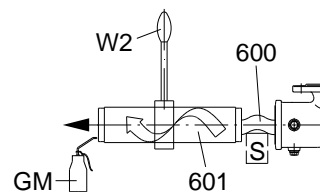

**9.1.2.3 Suction casing (500) - dismantling**

- Provide rotor (600) with protective cover (SH).
- Support rotor with base (S).
- Remove plug-in shaft pins (309).
- Dismantle the suction casing (500).

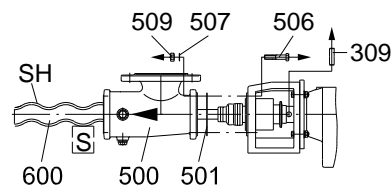

**9.1.2.4 Rotating unit (RTE) – dismantling**

**With flushing connection**



Tool (W10/ dismantling of the plug-in shaft)

- Remove the flushing connections (SSÜ) on the casing of the shaft seal (SEA).
- Pull the rotating unit (RTE) with shaft seal (SEA) off from the output shaft of the drive (ANT).
- Dismantle shaft seal (SEA).
  - Note dismantle shaft seal (chapter 9.\_).

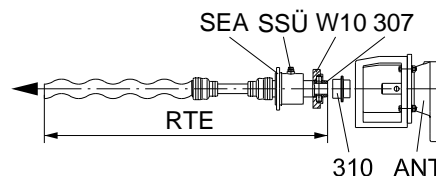

**Without flushing connection**



Tool (W10/ dismantling of the plug-in shaft)

- Pull rotating unit (RTE) with shaft seal (SEA) off from the output shaft of the drive (ANT).
- Dismantle shaft seal (SEA).
  - Note dismantle shaft seal (chapter 9.\_).

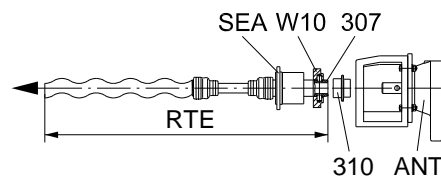

**9.1.2.5 Rotor (600), coupling rod (400), plug-in shaft (307) - dismantling**

- Dismantling joint (G)
  - Note rotating unit – individual parts (chapter 9.\_).

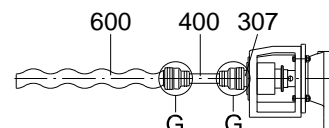

9.1.2.6 Lantern (200)/drive (ANT) - dismantling

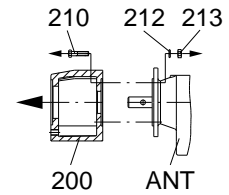

9.1.3 Reassembly

	<p><b>WARNING</b></p>	
	<p><b>Tilting or falling pump.</b> Death or serious injury can result.</p> <ul style="list-style-type: none"> <li>➤ Attach lantern (200) to secure the pump.</li> </ul>	

	<p><b>CAUTION</b></p>
	<p><b>Danger of fingers being crushed.</b> Slight injury may result.</p> <ul style="list-style-type: none"> <li>➤ Do not grasp between connections.</li> </ul>

9.1.3.1 Lantern (200)/drive (ANT) - reassembly

- Clean the flange bearing surfaces (FLS), bolt circle (ZD) and output pivots of the drive (ANT).

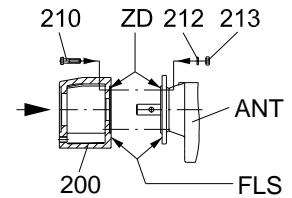

9.1.3.2 Rotor (600), coupling rod (400), plug-in shaft (307) - reassembly

- Joint (G) reassembly
  - Note rotating unit - individual parts (chapter 9\_).

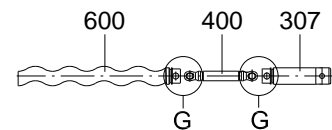

9.1.3.3 Rotating unit (RTE) - reassembly

- Assemble shaft seal carter (SEA).
  - Note reassembly shaft seal (chapter 9. \_).
- Moisten splash ring (310)/plug-in shaft (307) with joint grease.
- Slide splash ring (310) onto plug-in shaft (307).
  - Observe fitting position of splash ring (see writing on splash ring).
- Apply antiseize graphite petroleum to the output pivot of drive (ANT).
- Slide on rotating unit (RTE).

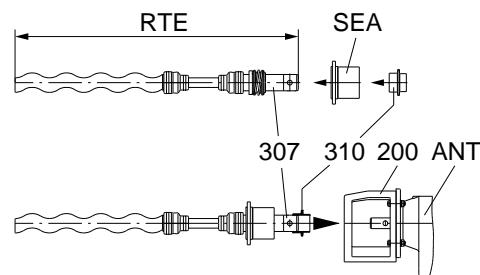

**With flushing connection**

- Mount the flushing connections.

9.1.3.4 Suction casing (500) - reassembly

- Provide rotor (600) with protective cover (SH).
- Support rotor (600) with base (S).
- Slide on casing gasket (501).
- Mount suction casing (500) and adjust (using spirit level).

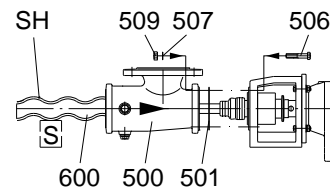

9.1.3.5 Stator (601) - reassembly

- Insert plug-in shaft pin (309).
- Twist plug-in shaft pin (309) upwards.

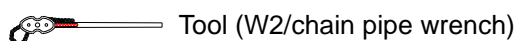
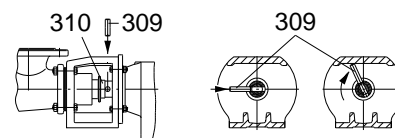

- Support rotor (600) with base (S).
- Add lubricant (GM) to the opening on the pressure branch side between the rotor (600) and stator (601).
- Turn stator (601) in the "right" rotating direction.
- Slide in plug-in shaft pins (309).
- Pay attention to the position of the splash ring (310).
- Insert the splash ring band at a distance of 0.5 mm from the lantern (200).

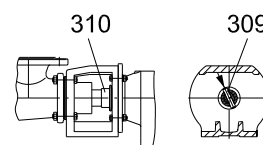
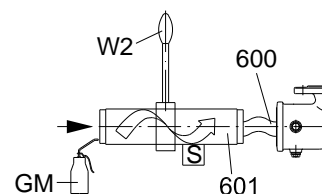

9.1.3.6 Pressure branch (700) - reassembly

- Tighten the tie bolts (602) evenly.

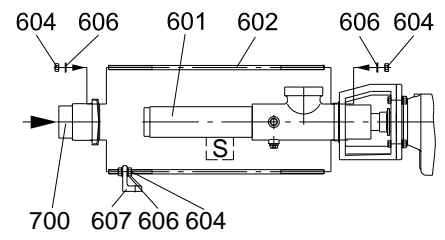

9.2 Rotating unit individual parts

9.2.1 Dismantling

9.2.1.1 Holding band (406, 407) - dismantling

	<p><b>CAUTION</b></p>
<p><b>Risk of injury.</b> Possibility of parts spinning out.</p> <ul style="list-style-type: none"> <li>➤ Wear protective goggles.</li> </ul>	

- Detach holding band loop (SCL).
  - Use suitable tool (WM).
- Push out parts of holding band loop (SCL).
- Remove holding band (406, 407).
- Pull back universal joint sleeve (405).

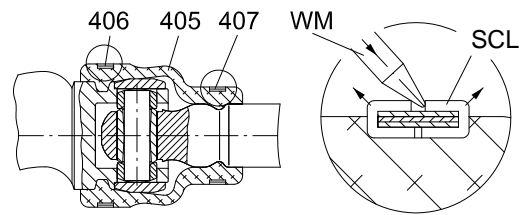

9.2.1.2 Retaining sleeve (401) - dismantling

- Knock back retaining sleeve (401).
  - Use suitable tool (WM).

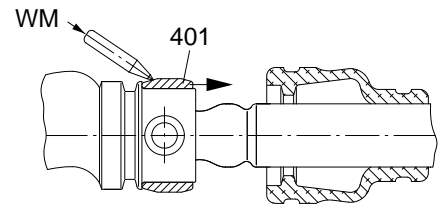

9.2.1.3 Detach joint

 Tool (W5/drift)

- Eject coupling rod pins (402).
- Bend (A) the coupling rod (400). Knock guide bushing (403) out with tool (W5).
- Remove coupling rod (400).

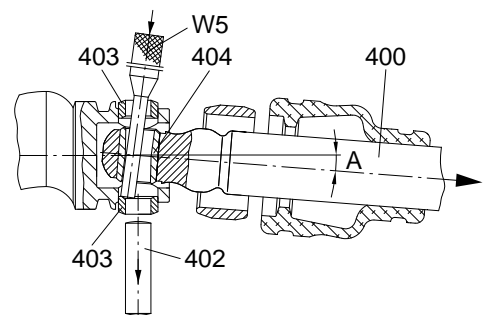

## 9.2.2 Rotating unit (RTE) - prepare individual parts for reassembly

## 9.2.2.1 Rotor (600)

- Remove any damage.
- Clean the rotor (600).

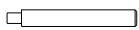
 Tool (W4/assembly mandrel)

- Press in the guide bushing (403) (depth = 2/3).
  - Use tool (W4).

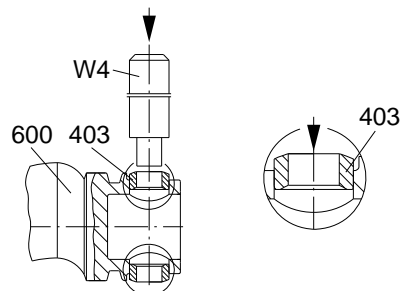

## 9.2.2.2 Coupling rod (400)

- Clean the coupling rod (400).
- Examine bore head for wear.
  - If wearing is detected on the bore head, replace the coupling rod (400).

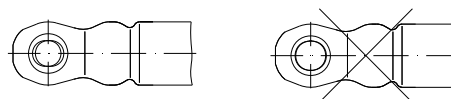

## 9.2.2.3 Plug-in shaft (307)

- Remove any damage.
- Clean the plug-in shaft (307).

 Tool (W4/assembly mandrel)

- Press in the guide bushing (403) (depth = 2/3).
  - Use tool (W4).

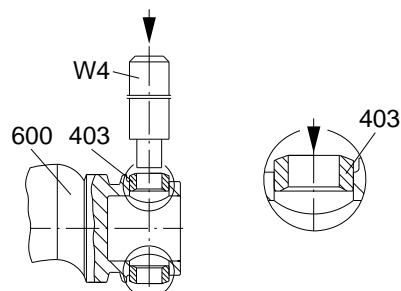

## 9.2.3 Rotating unit (RTE) - individual parts - reassembly

**NOTICE****Malfunction of the joints.**

Malfunction and/or destruction of joints.

- Replace the coupling rod pins (402) and guide bushings (403) jointly.

9.2.3.4 Coupling rod (400) – reassembly

- Slide the universal joint sleeve (405) and holding bands (406, 407) onto coupling rod (400).
- Fit the diameter and width of the holding band of the universal joint sleeve.
- Fill the joint head with seepex joint grease.

**Rotor (600)**

- Insert coupling rod pins (402).
- Slide on retaining sleeve (401).
- Connect the rotor/coupling rod.

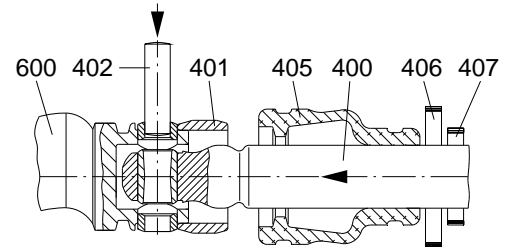

 Tool (W5/drift)

- Slide in the coupling rod pins (402).
- Knock the guide bushings (403) in.

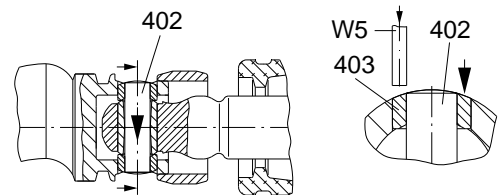

**Plug-in shaft (307)**

- Insert coupling rod pins (402).
- Slide on retaining sleeve (401).
- Connect the plug-in shaft/coupling rod.

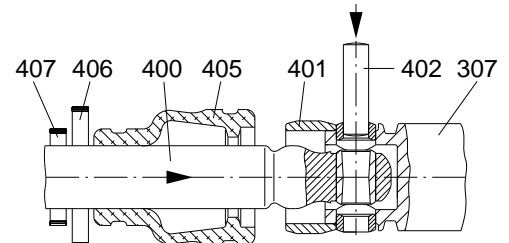

 Tool (W5/drift)

- Slide in the coupling rod pins (402).
- Knock the guide bushings (403) in.

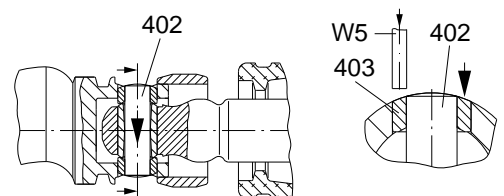

9.2.3.5 Retaining sleeve (401) - reassembly

 Tool (W4/assembly mandrel)

- Knock back retaining sleeve (401).
  - Use tool (W4).

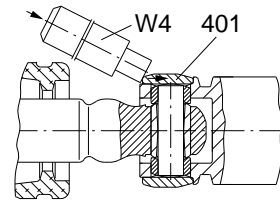

**Rotor (600) unhardened material**

- Secure retaining sleeve (401) in a displaced manner (2x180°).
  - Use suitable tool (WK).

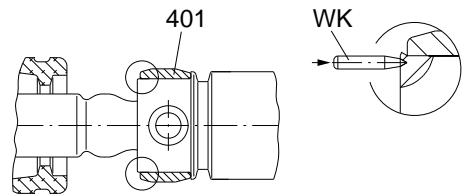

**Rotor (600) hardened material**

- Secure retaining sleeve (401) in a displaced manner (2x180°).
  - Use suitable tool (WK).

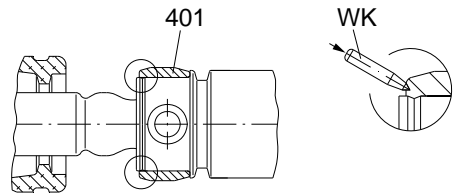

9.2.3.6 Universal joint sleeve (405) - reassembly

- Moisten the surface of the coupling rod (400)/ inner surface of the universal joint sleeve (405) with joint grease (maintenance, chapter 7.0).
- Slide on the universal joint sleeve (405).

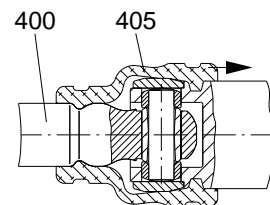

- Vent the interior of the joint.
  - Use suitable tool (WS).

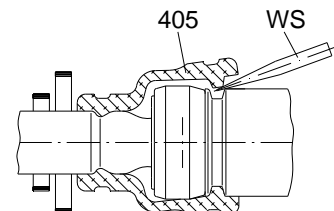

- Assemble holding band.
  - Holding band assembly (chapter 9.\_).

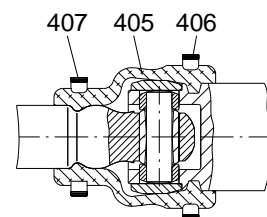

**9.3 Holding band - assembly**

**9.3.1 Prepare the holding band**

- Only use prefabricated double-band holding bands may.

**9.3.2 Check the holding band**

- Bent-over holding band (HBD) is in contact with holding band loop (SCL) to avoid damaging universal joint sleeve.
- Press on holding band (HBD) using tool (WZ) if necessary.

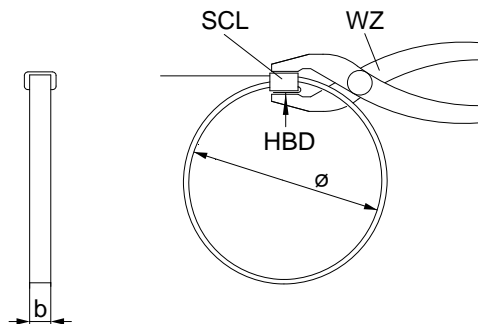

**9.3.3 Assemble the holding band**

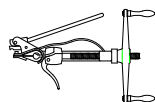

- Use tool (W3/mounting tool)

- Feed holding band into tool (W3).
- Hold ends of holding band with the eccentric lever (EX).
- Turn the crank (KU) until the holding band is strained and lies against the holding band loop (SCL).
- Carefully pull the holding band together until it is in contact with the circular groove of universal joint sleeve.

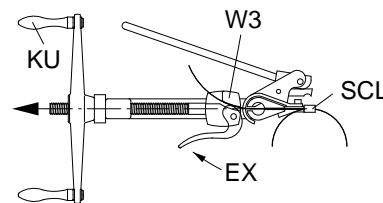

**9.3.4 Correct tension of the holding band (HBD)**

**Correct**

The holding band (HBD) has drawn in the out shape of the universal joint sleeve and is firmly seated.

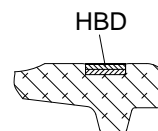

**Incorrect**

The holding band (HBD) is too loose, can slip off.

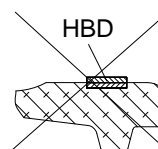

**Incorrect**

The holding band (HBD) is too tight, universal joint sleeve will be damaged/sheared off.

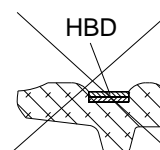

**9.3.5 Cant up the holding band**

- Swivel mounting tool (W3) approx. 60° upwards.
- Loosen crank (KU) by a half turn.
- Swivel cutting lever (SH) forward until the pressure piece is lying behind the holding band loop (SCL).

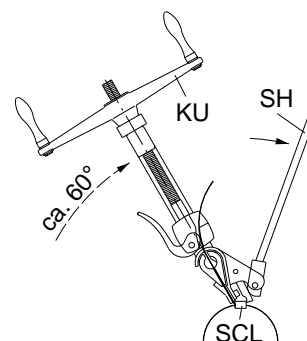

**9.3.6 Shear the holding band (material: 1.4301; 1.4571)**

- Hit the cutting lever (SH) with the inside of your hand.
  - Cant up and shear the end of the holding band behind the loop (SCL).
  - Carefully straighten up the holding band if it rises up on the sheared side.

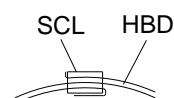

<b>CAUTION</b>
<p><b>Universal joint sleeve damage.</b> Pin joint grease can emerge.</p> <ul style="list-style-type: none"> <li>➤ Avoid hammering or knocking.</li> </ul>

**9.3.7 Check the holding band after assembly**

- The holding band must lie in the groove of the universal joint sleeve.
- Replace the holding band if the holding band slips back through the loop.

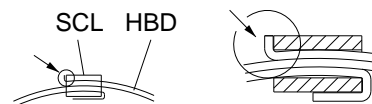

9.1 Shaft sealing single acting

9.1.1 Safety

	⚠ WARNING
<p><b>Shaft sealing is leaky.</b> Leakage may escape into the atmosphere.</p> <ul style="list-style-type: none"> <li>➤ Take safety measures to protect persons and the environment.</li> <li>➤ Wear suitable protective clothing.</li> <li>➤ Dispose of leakage appropriately.</li> <li>➤ Heed applicable regulations when handling hazardous substances.</li> </ul>	

9.1.2 Application conditions and material version

- Refer to the relevant application
  - technical data (Chapter 3.)

9.1.3 Design

- Single acting mechanical seal

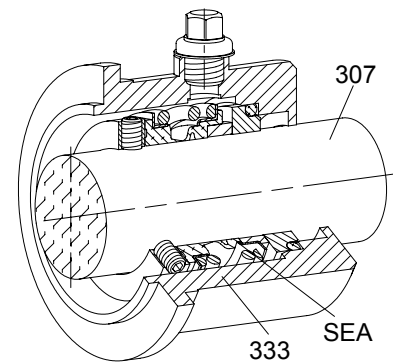

9.1.4 Commissioning

<b>NOTICE</b>
<p><b>Dry running of the mechanical seal.</b> Damage to property may result.</p> <ul style="list-style-type: none"> <li>➤ The mechanical seal must be laid in liquid medium before being commissioned.</li> </ul>

**Circulation, flushing and/or flushing pipe**

- Additional flushing or circulation pipes are not required where shaft sealing lies in medium.
- Flushing pipes may be possible under special circumstances and after speaking to seepex.

<b>NOTICE</b>
<p><b>Shaft sealing is not leakage free.</b> Damage to property through leakage.</p> <ul style="list-style-type: none"> <li>➤ Components which come into contact with leakage must be corrosion-resistant or otherwise suitably protected.</li> </ul>

**Adjust shaft sealing**

- It is absolutely vital to adjust at the application site in a manner appropriate for the application conditions.
- Refer to the sectional drawing of the shaft sealing for setting measurements.
- Set the setting measurements of the shaft sealing to the plug-in shaft (307).

9.1.5 Monitoring during operation

**NOTICE**

**Shaft wearing.**  
Damage to property may result.

- Conduct a daily visual inspection.
- Install a new shaft sealing (SEA).
- Possibly renew the plug-in shaft (307).

9.1.6 Dismantling of the mechanical seal

Refer to Data Sheet (Chapter 3.1)/sectional drawing of the shaft sealing (Chapter 9.) for version.

**With axial locking device**

- Clean plug-in shaft (307), remove edges/ burrs.
- Moisten plug-in shaft (307) with lubricant (thinned liquid soap).
- Pull mechanical seal casing (333) from the plug-in shaft (307).
- Loosen the axial locking device of the mechanical seal (330/372); pull mechanical seal (330) from the plug-in shaft (307).
- Push counter ring of the mechanical seal (330G) with seal out of the mechanical seal casing (333).

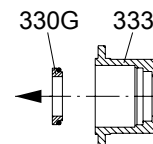
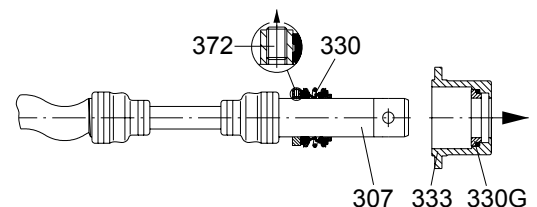

**Without axial locking device**

- Clean plug-in shaft (307), remove edges/ burrs.
- Moisten plug-in shaft (307) with lubricant (thinned liquid soap).
- Pull mechanical seal casing (333) from the plug-in shaft (307).
- Pull the mechanical seal (330) from the plug-in shaft (307).
- Push counter ring of the mechanical seal (330G) with seal out of the mechanical seal casing (333).

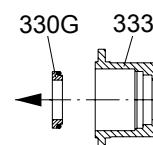
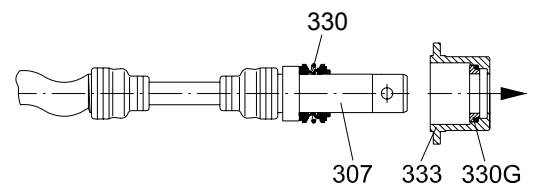

**9.2 Reassembly of mechanical seal**



Shaft sealings are premium precision parts.  
 Their installation is therefore to be undertaken with care.  
 Gentle handling and the utmost of cleanliness are prerequisites.

- Assembly aids such as oil/grease are not permitted.

**With axial locking device**

- Clean the mechanical seal casing (333).
- Moisten seal with lubricant (thinned liquid soap).
- Press counter ring and seal using even pressure into the mechanical seal casing (333).
- Clean the plug-in shaft (307), remove edges/burrs.
- Adjust the set collar (372) in accordance with sectional drawing of shaft sealing (Chapter 9. \_).
- Stick the set screw on (medium torque) and anchor.
- Moisten plug-in shaft (307) and Elastomer parts of the mechanical seal with lubricant (thinned liquid soap).
- Push mechanical seal casing (333) onto the plug-in shaft (307) until the plant edge has been reached.

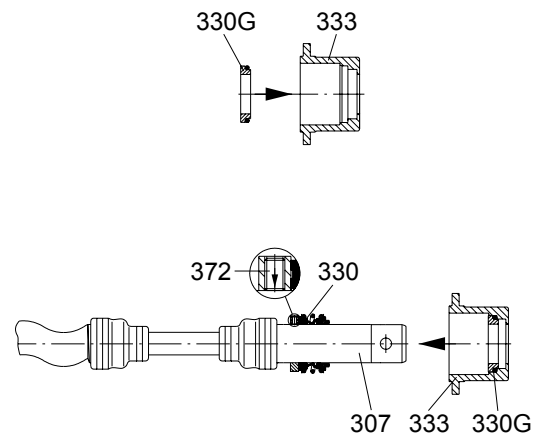

**Without axial locking device**

- Clean the mechanical seal casing (333).
- Moisten the seal with lubricant (thinned liquid soap).
- Press the counter ring and seal using even pressure onto the mechanical seal casing (333).
- Clean the plug-in shaft (307), remove edges/burrs.
- Adjust mechanical seal in accordance with sectional drawing of shaft sealing (Chapter 9. \_) to the plug-in shaft (307).
- Moisten plug-in shaft (307) and Elastomer parts with lubricant (thinned liquid soap).
- Slide mechanical seal onto the plug-in shaft (307) until the plant edge has been reached.

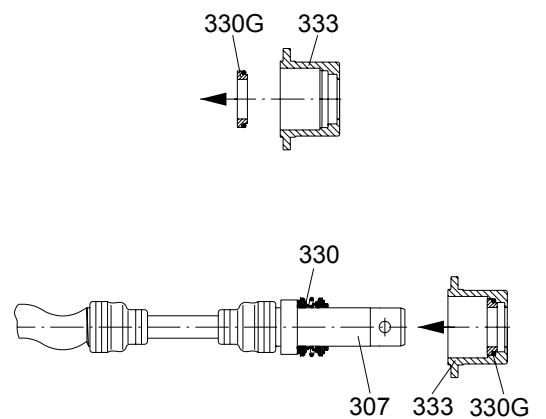

## 9.1 Mechanical seal general

## 9.1.1 Safety

	<b>⚠ WARNING</b>
	<p><b>Shaft seal is leaky.</b> Leakage emerges to atmosphere.</p> <ul style="list-style-type: none"><li>➤ Take safety measures to protect persons and the environment.</li><li>➤ Wear suitable protective clothing.</li><li>➤ Dispose of leakage appropriately.</li><li>➤ Heed applicable regulations when handling hazardous substances.</li></ul>

## 9.1.2 Operating conditions and material combination

- Adjust to the relevant application
  - Refer to technical data (chapter 3)

**10.1 Version for copying**

**10.2 Sectional Drawing and Part List**

10.1 Version for copying

10.2 Spare parts list

Spare parts can be ordered online or requested from  
www.seepex.com\service\ersatzteile\

Type: BN 05-24 to 300-6L

<input type="checkbox"/> Request	<input type="checkbox"/> Order	Sender:
Must be included in every order or enquiry!		Contact: .....
Commission:	Type:	Tel.: .....
_____	_____	Fax: .....
		E-mail: .....

Customer service: seepex GmbH Postfach 10 15 64 D-46215 Bottrop service@seepex.com	Germany	Tel +492041.996-231 Fax +492041.996-431	Delivery address: ..... ..... ..... .....
	Europe outside Germany	Tel +492041.996-224 Fax +492041.996-424	
	Intercontinental outside Germany	Tel +492041.996-120 Fax +492041.996-432	

No.	Quantity	Component	Material	Comment
<b>Minor set of wearing parts</b> <input type="checkbox"/>				
301	1	Set of packing rings		according to data sheet (chapter 3.1)
311	1	Rinse ring		
330	1	Mechanical seal		according to data sheet (chapter 3.1)
601	1	Stator		

No.	Quantity	Component	Material	Comment
<b>Major set of wearing parts</b> <input type="checkbox"/>				
301	1	Set of packing rings		according to data sheet (chapter 3.1)
307	1	Plug-in shaft		
330	1	Mechanical seal		according to data sheet (chapter 3.1)
400	1	Coupling rod with coupling rod bushings		
402	2	Coupling rod pin		
403	4	Guide bushing		
405	2	Universal joint sleeve		
406	2	Holding band, large		
407	2	Holding band, small		
600	1	Rotor		
601	1	Stator		

Place, date

Signature / company stamp

10.3 Version for copying

No.	Quantity	Component	Material	Comment
<b>Set of gaskets</b> <input type="checkbox"/>				
301	1	Set of packing rings		according to data sheet (chapter 3.1)
310	1	Splash ring		according to data sheet (chapter 3.1)
330	1	Mechanical seal		
501	1	Casing gasket		
503	3	Sealing ring		
511	2	O-ring/cleaning cover		
517	2	Sealing ring		
706	1	Sealing ring		

No.	Quantity	Component	Material	Comment
<b>Plug-in shaft &amp; shaft seal</b> <input type="checkbox"/>				
301		Set of packing rings		according to data sheet (chapter 3.1)
307		Plug-in shaft		
309		Plug-in shaft pin		
310		Splash ring		according to data sheet (chapter 3.1)
330		Mechanical seal		according to data sheet (chapter 3.1)

No.	Quantity	Component	Material	Comment
<b>Coupling rod &amp; joint parts</b> <input type="checkbox"/>				
400		Coupling rod with coupling rod bushings		
401		Retaining sleeve		
402		Coupling rod pin		
403		Guide bushing		
405		Universal joint sleeve		
406		Holding band, large		
407		Holding band, small		
401-407		Complete set of joint parts		

\_\_\_\_\_  
Place, date

\_\_\_\_\_  
Signature / company stamp

10.4 Version for copying

No.	Quantity	Component	Material	Comment
<b>Pumping elements</b>			<input type="checkbox"/>	
600		Rotor		
601		Stator		
No.	Quantity	Component	Material	Comment
<b>Miscellaneous parts</b>			<input type="checkbox"/>	
501		Casing gasket		
098		Pin joint grease		1 cartridge = 300 g (approx. 315 cm <sup>3</sup> ) Grease quantity according to maintenance (chapter 7.0)

\_\_\_\_\_  
Place, date

\_\_\_\_\_  
Signature / company stamp

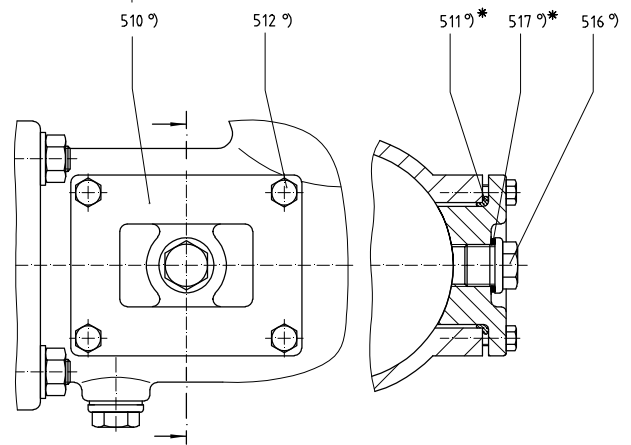
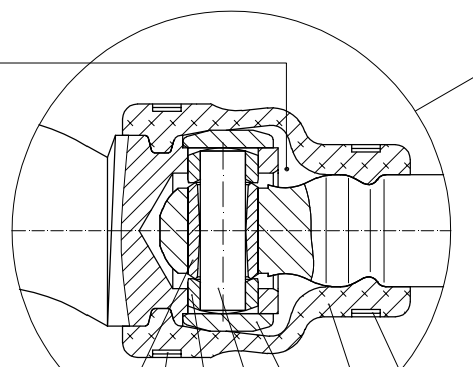
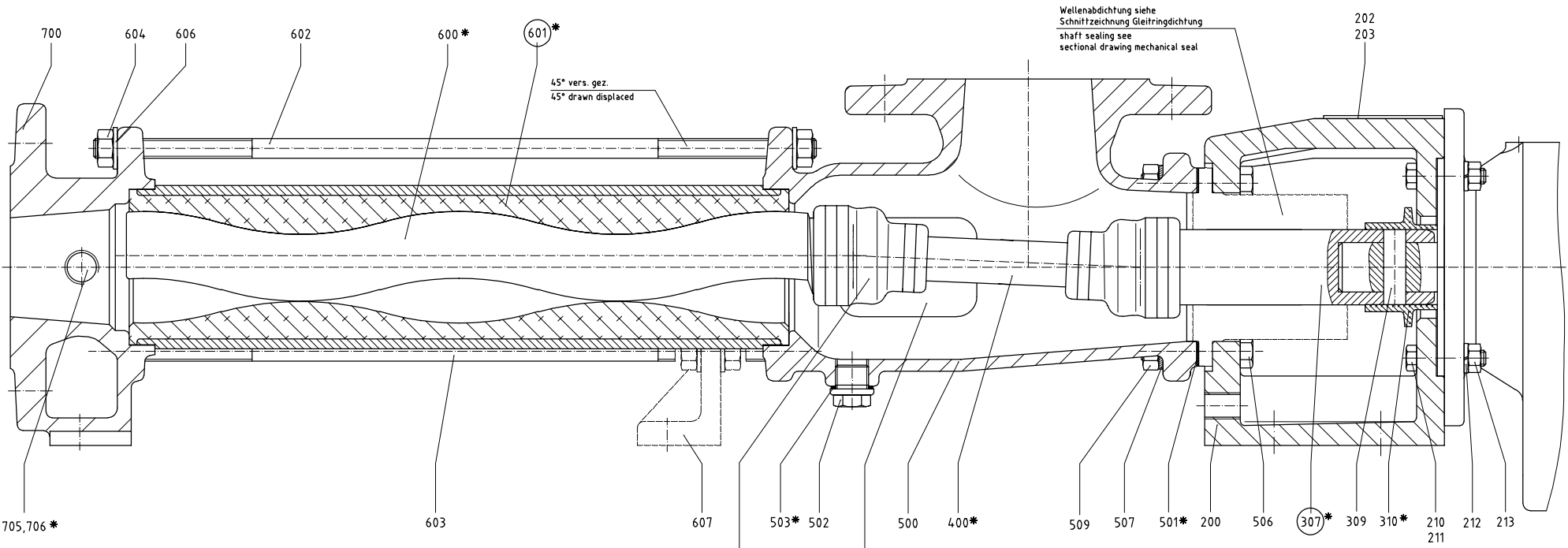

098\*  
seepex Gelenkfett  
Typ und Füllmenge:  
Betriebs- und Wartungsanleitung  
entnehmen  
  
seepex joint grease  
type and filling quantity:  
see operating and  
maintenance instruction

Wellenabdichtung siehe  
Schnittzeichnung Gleitringdichtung  
shaft sealing see  
sectional drawing mechanical seal

° Option / option

Stapel-Numm. DW	Norm Standard	Benennung/Denomination Zeilungs-/Nummer/ Drawing-Number	Werkstoff/Material	Bemerkung/Remark	Gezeichnet DW
--------------------	------------------	---	--------------------	------------------	------------------

**seepex.com**

Abgleichkennzeichen DW 02 1302	Reparatur Name	Datum Date	Werkstoff/Code Material	Werkstoff/Material	Gewicht/Weight
AD 372	df	16.11.2002	%		

Bezeichnung/Denomination  
**Schnittzeichnung Baureihe "BN"**  
sectional drawing range "BN"

Rechnung für Überprüfungen DW 02 1302	Name Name	Datum Date	Zeilungs-/Nummer/ Drawing-Number
Reparatur/Reparatur Name <td>huf</td> <td>16.02.1995</td> <td>062-004B1</td>	huf	16.02.1995	062-004B1
Geprüft/Checked Name	huf	16.02.1995	062-004B1
DW 02 1302	Normen/Standard	Gezeichnet/Drawn by	Gezeichnet durch/Drawn by:

Urheberrechtsschutz: Diese Zeichnung ist unser Eigentum und wird nach dem Gesetz über Urheberrecht und verwandte Schutzrechte geschützt.  
Protection of Copyright: This drawing is our property and is protected acc. to the law referring to copyright and related protective laws.

○ Werkzeug  
Betriebs- und Wartungsanleitung  
entnehmen  
  
tool  
see operating and  
maintenance instruction

\* Verschleißteile und Dichtungen  
Betriebs- und Wartungsanleitung  
entnehmen  
  
Wearing parts and sealings  
see operating and  
maintenance instruction

Stck.	Pos.	DE	EN	FR
		Baureihe BN	Range BN	Série BN
		Schnittzeichnung Nr. 062-004_1	sectional drawing no. 062-004_1	plan no. 062-004_1
		Benennung Stck. / Pos.	denomination Qty. / Item	désignation Qté. / Poste
1	200	Laterne	lantern	lanterne
2	202	Halbrundkerbnägel	round head grooved pins	rivet
1	203	Typenschild	type plate	palque signalitique
4	210	6kt-Schraube	hexagon bolt	vis
	211	6kt-Schraube	hexagon bolt	vis
4	212	Federring	spring washer	rondelle frein
4	213	6kt-Mutter	hexagon nut	écrou
1	307	Steckwelle	plug-in shaft	arbre à broche
1	309	Steckwellenbolzen	plug-in shaft pin	cheville pour arbre à broche
1	310	Spritzring	splash ring	bague de projection
1	400	Kuppelstange	coupling rod	barre d' accouplement
2	401	Gelenkhülse	retaining sleeve	douille d' articulation
2	402	Kuppelstangenbolzen	coupling rod pin	axe d' articulation
4	403	Führungsbuchse	guide bushing	douille de guidage
2	404	Kuppelstangenbuchse	coupling rod bushing	chemise d' axe
2	405	Manschette	universal joint sleeve	manchette
2	406	Halteband	holding band	collier de serrage
2	407	Halteband	holding band	collier de serrage
1	500	Sauggehäuse	suction casing	carter d' aspiration
1	501	Sauggehäusedichtung	casing gasket	étanchéité du carter d' aspiration
3	502	Verschlusschraube	screwed plug	bouchon de vidange
3	503	Dichtring	sealing ring	joint d' étanchéité
4	506	6kt-Schraube	hexagon bolt	vis
4	507	Fächerscheibe	fan type lock washer	rondelle à dents chevauchantes extérieures
4	509	6kt-Mutter	hexagon nut	écrou
2	°) 510	Reinigungsdeckel	cleanout	couvercle de nettoyage
2	°) 511	Dichtung	gasket	étanchéité
8	°) 512	6kt-Schraube	hexagon bolt	vis
2	°) 516	Verschlusschraube	screwed plug	bouchon de vidange
2	°) 517	Dichtring	sealing ring	joint d' étanchéité
1	600	Rotor	rotor	rotor
1	601	Stator	stator	stator
2	602	Spannschraube	tie bolt	tirant
2	603	Spannschraube	tie bolt	tirant
8	604	6kt-Mutter	hexagon nut	écrou
8	606	Scheibe	washer	rondelle
1	607	Stützbock	trestle	ped
1	700	Druckstutzen	pressure branch	bride de refoulement
1	705	Verschlusschraube	screwed plug	bouchon de vidange
1	706	Dichtring	sealing ring	joint d' étanchéité

		DE	EN	FR
		<b>Baureihe BN</b>	<b>Range BN</b>	<b>Série BN</b>
		<b>Schnittzeichnung Nr. 062-004_1</b>	<b>sectional drawing no. 062-004_1</b>	<b>plan no. 062-004_1</b>
<b>Stck.</b>	<b>Pos.</b>	<b>Benennung Stck. / Pos.</b>	<b>denomination Qty. / Item</b>	<b>désignation Qté. / Poste</b>
	098	seepex Gelenkfett Typ und Füllmenge: Betriebs- und Wartungsanleitung entnehmen	seepex joint grease type and filling quantity: see Operating and Maintenance Instruction	seepex graisse d' articulations sommaire pour type et quantité: voir Instructions de service et d'entretien
		Verschleißteile und Dichtungen: Betriebs- und Wartungsanleitung entnehmen	Wear parts and sealings: see Operating and Maintenance Instruction	pièces d'usure et étanchéités: voir Instructions de service et d'entretien
		Werkzeuge: Betriebs- und Wartungsanleitung entnehmen	Tools: see Operating and Maintenance Instruction	Outils: voir Instructions de service et d'entretien
		Wellenabdichtung siehe Schnittzeichnung Gleitringdichtung	shaft sealing see sectional drawing mechanical seal	dispositif d' etanchéité voir vue éclatée garniture mécanique
		versetzt gezeichnet	drawn displaced	plan séparé
	°)	Option	option	option

## 11.1 Master copy

Spare parts can be ordered online or requested from  
www.seepex.com\services\ersatzteile\

**Must be specified with every order!**

Commission: \_\_\_\_\_

Mark tool!

**X**

Sender:



Contact: .....



Tel.: .....

Fax: .....

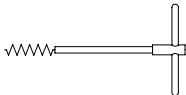
E-mail: .....

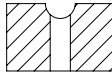
Customer service: seepex GmbH Postfach 10 15 64 D-46215 Bottrop service@seepex.com	Germany	Tel +492041.996-231 Fax +492041.996-431	Delivery address: ..... ..... ..... .....
	Rest of Europe	Tel +492041.996-224 Fax +492041.996-424	
	Outside Europe	Tel +492041.996-120 Fax +492041.996-432	

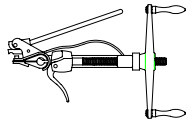
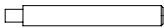
For installation of:	Packing gland	Stator	Coupling rod bushings
Tool no.	W1 <input type="checkbox"/>	W2 <input type="checkbox"/>	W14 <input type="checkbox"/>
Denomination:	Packing lever	Chain pipe wrench + replacment chain	Pressing tool
Order no.	PKZ	KRZ	PWZ
			

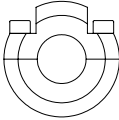
For installation of:	Rotating unit			
	Holding band	Joint	Joint	Plug-in shaft
Tool no.	W3 <input type="checkbox"/>	W4 <input type="checkbox"/>	W5 <input type="checkbox"/>	W10 <input type="checkbox"/>
Denomination:	Mounting tool	Assembly mandrel	Drift	Dismantling Tool
Order no.	MHB	MTD	DHS	AZV
				

For installation of:	General		
Tool no.	W9 <input type="checkbox"/>		
Denomination:	Mounting lever		
Order no.	MHL		
			

**12.1 Additional components**

**12.2 Technical information**

**Information:**

Eine GLRD wird gequenchet bei Medien die zu Kristallisation an den Gleitflächen neigen, bzw. adhäsiv sind. Desweiteren ist Quenchung bei Vakuum Betrieb zur Vermeidung von Trockenlauf erforderlich. Die Quenchflüssigkeit muss mit dem Fördermedium verträglich und auf die Werkstoffe der GLRD abgestimmt sein.

**Achtung: Quenchflüssigkeit drucklos fahren, max 0,1 - 0,15 bar.  
Bei größerem Druck Ausrücksicherung für Wellendichtring erforderlich, siehe HA.RDO.02.**

**Inbetriebnahme und Wartung:**

- a) prüfen ob Quenchflüssigkeit / (Lieferzustand) mit Medium verträglich ist. Bei Nicht-verträglichkeit ist eine geeignete Quenchflüssigkeit nach vollständiger Entleerung einzufüllen.
- b) Quenchflüssigkeitsmenge prüfen / nachfüllen und Quenchkammer durch öffnen der Verschlusschraube (E) entlüften.

**Information:**

A mechanical seal is quenched, when the medium (product) tends to crystallization at the seal faces, or when it is adhesive. Moreover, quenching is necessary during vacuum-operation to avoid dry-running. The quench liquid must be compatible with the pumped product and with the selected material of the mechanical seal.

**Attention: Quench liquid is used pressureless, max 0,1 - 0,15 bar.  
Regarding higher pressure, a disengaging device is required for the shaft sealing ring, see HA.RDO.02.**

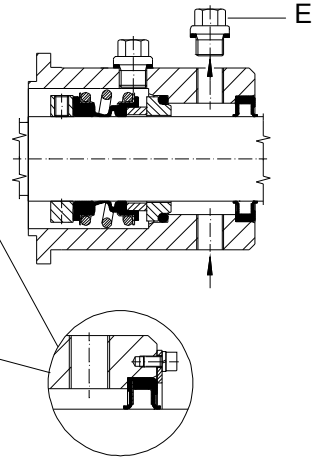

**Commissioning and Maintenance:**

- a) Check, if the quench liquid / (supplied with the pump) is compatible with the pumped product. If not, a suitable quench liquid has to be filled in after complete drain.
- b) Quench liquid has to be checked / refilled. Quench chamber has to be deaerated by opening the sealing screw (E).

**Ausführung 1**

Beistellung und Anbau des Flüssigkeitsbehälters durch den Kunden:  
Die Quenchkammer ist bei Auslieferung mit Kühl-/Schmiermittel **seepex 50300** (Glycerin) <sup>1)</sup> bzw. bei Lebensmittelausführung mit **seepex 60200**<sup>1)</sup> gefüllt und beidseitig mit Verschlusschrauben verschlossen.

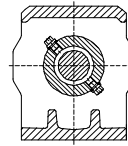

**Design 1**

Liquid tank provided and mounted by the customer:  
Quench chamber is filled with **seepex 50300** (Glycerin) <sup>1)</sup>, for food design with **seepex 60200** <sup>1)</sup> and locked-up with sealing screws on both sides.

**Ausführung 2** nicht mehr im Lieferprogramm / **design 2** is no more contained in our product program

**Ausführung 3**

Mit nachfüllbarem Vorlagebehälter  
Die Quenchkammer ist mit Kühl-/Schmiermittel **seepex 50300** (Glycerin) <sup>1)</sup> bzw. bei Lebensmittelausführung mit **seepex 60200**<sup>1)</sup> gefüllt, der Behälter ist leer und muss vor Inbetriebnahme aufgefüllt werden.

- Vorlagebehälter: 3 = Messing vernickelt, Plexiglas, NBR  
3A = Ausführung ATEX: Messing vernickelt, Glas, NBR  
3.1A = Ausführung ATEX: Messing vernickelt, Glas, NBR, mit Schutzrohr

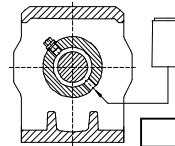

Baugröße / size	
0005-24 - 1-6L	1-12 - 500-6LA
ca. 80 cm <sup>3</sup>	ca. 140 cm <sup>3</sup>

**Design 3**

With refillable supply tank.  
Quench chamber is filled with **seepex 50300** (Glycerin) <sup>1)</sup>, for food design with **seepex 60200** <sup>1)</sup>, container is empty and has to be filled before commissioning.

- Supply tank: 3 = brass nickel plating, plexiglass, NBR  
3A = design ATEX: brass nickel plating, glass, NBR  
3.1A = design ATEX: brass nickel plating, glass, NBR, with protection tube

**Ausführung 4**

Mit nachfüllbarem Vorlagebehälter.  
Die Quenchkammer ist mit Kühl-/Schmiermittel **seepex 50300** (Glycerin) <sup>1)</sup> bzw. bei Lebensmittelausführung mit **seepex 60200**<sup>1)</sup> gefüllt, der Behälter ist leer und muss vor Inbetriebnahme aufgefüllt werden.

- Vorlagebehälter: 4.1 = Messing vernickelt, Plexiglas, NBR  
4.2 = Polyethylen  
4.1A = Ausführung ATEX: Messing vernickelt, Glas, NBR  
4.2A = Ausführung ATEX: Edelstahl

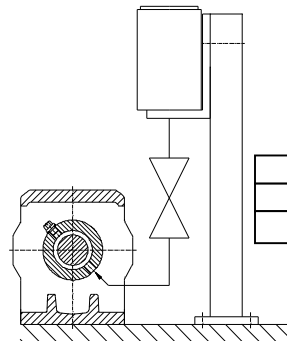

Baugröße / size
1-12 - 500-6LA
0,5L alternativ 4L / 3L

**Design 4**

With refillable supply tank.  
Quench chamber is filled with **seepex 50300** (Glycerin) <sup>1)</sup>, for food design with **seepex 60200** <sup>1)</sup>, container is empty and has to be filled before commissioning.

- supply tank: 4.1 = brass nickel plating, plexiglass, NBR  
4.2 = Polyethylen  
4.1A = design ATEX: brass nickel plating, glass, NBR  
4.2A = design ATEX: stainless steel

Ausführung Design	Füllmenge Quantity
4.1 / 4.1A	0,5 L
4.2 / 4.2A	4 L / 3 L

**Lage der Einlassstellung für alle Ausführungen:**

**Location of inlet position for all designs:**

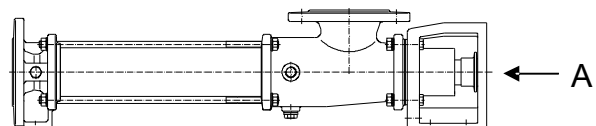
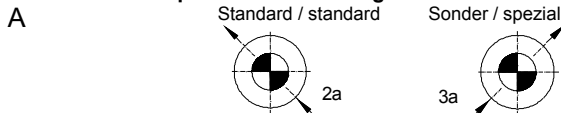

1) Quenchflüssigkeit bei Standardausführung, andere Quenchflüssigkeit nach Bedarf.  
Quench liquids regarding standard design, other quench liquids upon request.

## 1 Area of application

Conveying liquids with the following properties

- aggressive, toxic
- sticky, highly viscous
- polymerising
- tendency to leave deposits
- high vapour pressure or gaseous
- high pressure, high temperature

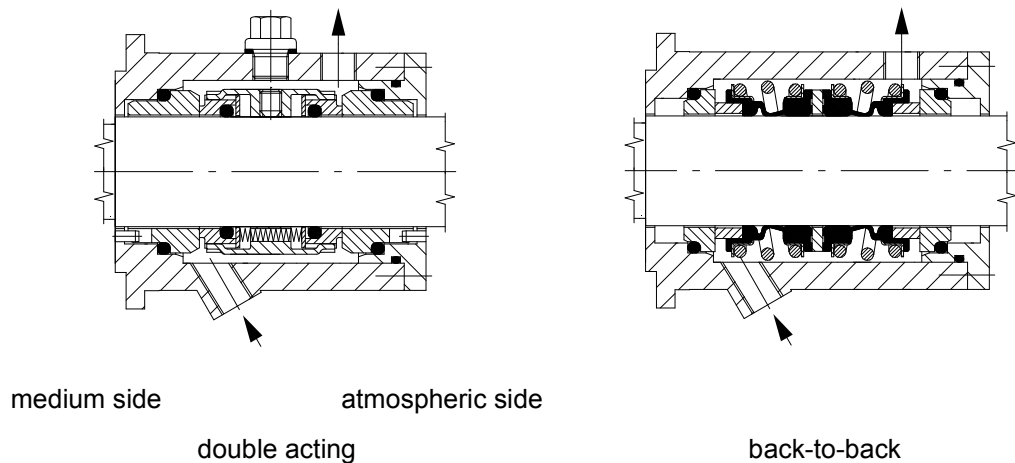

## 2 Buffer fluid

### 2.1 General

The buffer fluid fills the space between the set of mechanical seals on the medium side and the atmospheric side

### 2.2 Task

- to dissipate the corresponding frictional heat.
- to avoid infiltration of the product into the sealing gap.

### 2.3 Medium

- clean, cold and stable liquid is used, e.g. water.
- it must be compatible with the product and free of solids.
- it must not have a tendency to leave deposits.
- it should have low viscosity and a good thermal conductivity.
- Bear in mind the resistance to corrosion of all contact parts.

### 2.4 Pressure

The buffer fluid pressure must always be 1,5-2 bar greater than the maximum product pressure. This ensures that infiltration of the product in the mechanical seal (GLRD) sealing gap is prevented.

### 3 Buffer system in accordance with API 610, Plan 53 and Plan 54

Functions

- Pressure build-up in the buffer area
- Leakage compensation
- Agitation of the buffer fluid
- Colling of the buffer fluid

#### 3.1 Buffer system natural circulation (thermosyphon principle) API Plan 53

Thermosyphon vessel (TS)

Agitation - natural circulation

Cooling and leakage compensation in the TS vessels

Pressure function:

with nitrogen (N<sub>2</sub>)

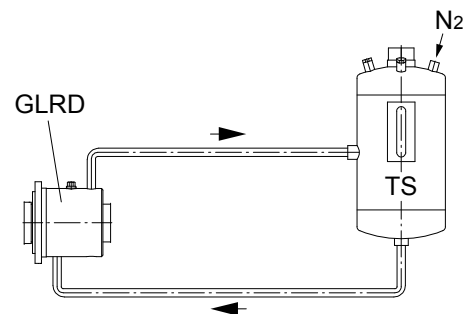

- Requisite buffer pressure in the mechanical seal (GLRD)
  - at least 1,5-2 bar above the maximum pressure in the pump suction casing.

#### 3.2 Seal flush supply from an external system API Plan 54

- 1 Pressure reducing valve
- 2 Shut-off valve
- 3 Pressure manometer
- 4 Shut-off valve

GLRD mechanical seal

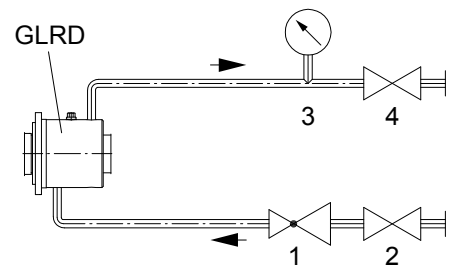

- Requisite buffer pressure in the mechanical seal (GLRD)
  - at least 1,5-2 bar above the maximum pressure in the pump suction casing.

13.1 Manufacturer's documents / suppliers

- available



## Europe:

### Great Britain

seepex UK Ltd.  
3 Armtech Row  
Houndstone Business Park  
Yeovil Somerset BA22 8RW  
Tel +44.19 35.47 23 76  
Fax +44.19 35.47 98 36  
sales@seepex.co.uk

### Austria

seepex GmbH  
Sales Office Austria  
Obermüllergasse 18  
A-3003 Gablitz  
Tel +43.22 31.6 10 85  
Fax +43.22 31.6 10 85 20  
hfriedl@seepex.com

### Belgium

seepex GmbH  
Bureau Belgique/Belgique  
Industriezone Klein Gent-Link 21  
Welvaartstraat 14-1 bus 15  
Tel +32.14.50 14 71  
Fax +32.14.50 14 61  
seepex.be@seepex.com

### Denmark

seepex Nordic AS  
Bakkegardsvej 411  
DK-3050 Humlebaek  
Tel +45.49 19 22 00  
Fax + 45.49 19 32 00  
infor@seepex.dk

### France

seepex France SARL  
1, Rue Pelloutier  
F-77183 Croissy Beaubourg  
Tel. +33.1.64 11 44 50  
Fax + 33.1.64 11 44 89  
info.fr@seepex.com

### Ireland

seepex UK Ltd.  
Branch Office Ireland  
No 5 Arden Glas  
Portlaoise  
Co. Laois  
Tel. +353.5 78 68 18 26  
Fax +353.5 78 68 15 87  
mryan@seepex.co.uk

### Italien

seepex GmbH  
Ufficio de Rappresentanza per l'Italia  
Piazza Luigi di Savolia, 22  
20124 Milano  
Tel +39.02.36 56 93 60  
Fax +39.02.92 87 78 53  
info.it@seepex.com

### Schweden

seepex Nordic A/S  
Hamndalsvägen 58  
S-61633 Åby  
Tel +46.116.69 40  
Fax +46.116.69 41

### Spain

seepex GmbH  
C/Copenhagen, 12  
Edif. Tifan Oficina 207  
28232 La Rozas  
Madrid  
Tel +34.91.636.13.53  
Fax +34.91.640.93.71  
jspoerck@seepex.com

### The Netherlands

seepex GmbH  
Bureau Nederland  
Maagdenburgstraat 22c  
NL-7421 ZC Deventer  
Tel +31.570.51.66 44  
Fax +31.570.51 60 77  
seepex.nl@seepex.com

## North America:

### USA

seepex INC.  
5100 Speedway Drive  
Enon Ohio 45323  
Tel.+1.937.8 64 71 50  
Fax + 1.937.64 71 57  
sales@seepex.net

## Asia:

### China

seepex Pumps (Shanghai) Co., Ltd.  
Xuanzhong Industrial Area  
201300 Shanghai  
Tel +86.21.38 10 88 88  
Fax +86.38 10 88 99  
info.cn@seepex.com

### India

seepex India Pvt. Ltd.  
Office No. 305.  
Raheja Arcade Building  
Sector 11, C.B.D. Belapur  
Navi Mumbai 400614  
Tel +91.22.4024 0434/35  
Fax +91.22.4024 0436  
info.ind@seepex.com

### Japan

seepex Japan Co., LTD.  
Keyaki Building  
Nakano-sakaue #101,  
2-31-5 Chuo, Nakano-ku,  
Tokyo 164-0011  
Tel +81.3.57 55 59 71  
Fax +81.3 57 55 59 72  
info.jp@seepex.com

### Malaysia

seepex (M) Sdn. Bhd.  
59-1, Jalan PJU 1/37  
Dataran Primo  
47301 Petaling Jaya  
Selengor Darul Ehsan  
Tel +60.3.78.80 69 51  
Fax +60.3.78 80 69 59  
seepex.m@seepex.com

More seepex sales partners in Europe,  
America, Asia, Africa and Oceania  
you will find on our website.

And what can we get flowing for you?  
Your nearest contact:

Or visit [www.seepex.com](http://www.seepex.com)