

GENERAL

These operating instructions are intended to help you install and operate the drive. For trouble free service, proper installation and operation are essential. Additionally, these instructions contain important recommendations on maintenance.

Before shipment, every SEW-Eurodrive unit is thoroughly tested, checked, and properly packed. However, please inspect the drive immediately upon arrival for shortage or transit damage. Note any damage or shortage on the freight bill of lading and file a claim with the carrier. Also, notify SEW-Eurodrive of the shortage or damage.

Installation

VARIGEAR® units may be foot mounted, flange mounted or attached to a gear unit. The drive installation site should be selected to ensure:

- Ambient temperatures below 40°C (104°F).
- Unimpeded flow of air to the motor and variable speed unit.
- Accessibility of the gear unit's oil plugs.
- Adequate space for the removal of the brakemotor fan guard for brake adjustment and maintenance.

The drive unit should be mounted on a flat, vibration damping and torsionally rigid structure. Careful alignment is critical. Mounting to an uneven surface will cause housing distortion. The flatness tolerance of the supporting surface should not exceed:

Foot mounted beltcases size VU/VZ 41 and smaller - 0.004 inch
Foot mounted beltcases size VU 51, 6 - 0.008 inch
For gear unit mounting, see the Gear Reducers Operating Instructions.

Installation of Couplings, Sprockets, Sheaves, Etc.

Do not hammer on the shafts. Hammering can cause brinelling of the bearings and a reduction in bearing life.

We recommend heating the components to approximately 175°F and sliding them on. This will reduce possible damage to the output shaft bearings. In addition, there is a metric tapped hole in the center of the motor shaft that can be utilized with a tool to press on or remove the coupling, sheaves, etc.

The VARIGEAR® shaft diameters are metric and have tolerances as listed in the SEW-Eurodrive catalogs. Shaft couplings should be properly aligned to prevent vibration, coupling wear and premature failure of the shaft bearings.

Maximum Parallel Offset 0.003 inch
Maximum Angular Offset 0.030°

To prevent the output shaft and bearings from being subjected to excessive loads, do not exceed the maximum overhung load shown in the SEW-Eurodrive catalog. Please consult our engineering department if the load will exceed the recommended figure given or where there are combined radial and axial loads. In such cases, the exact operating conditions must be stated including speed, direction of rotation, magnitude, and direction of the external radial and axial loads being applied.

Severe Duty Units

Severe Duty units include drain holes in the beltcase housing at the lowest points allowing condensation to drain out of the variable speed housings.

CAUTION! The drain holes are installed for the mounting position listed on the gearbox nameplate. Installing a unit in a mounting position other than what is shown on the nameplate will reposition the condensation drain holes. As a result, the drain holes may not be located at the lowest point and may not allow water to drain. This can cause premature drive failure.

Operation

VARIGEARs® are shipped with the speed setting adjusted for minimum output rpm.

WARNING! DO NOT adjust the speed unless the main drive motor is running. Failure to comply may cause damage to the belt.

For manually controlled units, the speed is increased by turning the handwheel (sprocket, spindle, etc.) clockwise.

On units with right angle control heads, the speed range may be reduced from the factory set maximum. Run the unit to the minimum or maximum desired speed. Remove the steel cover - #1, on the control head and loosen the nut - #2, on the appropriate speed stop bolt. Slide the stop bolt against the spindle guide nut - #3, and re-tighten the speed stop nut. Repeat for the other end of the speed range.

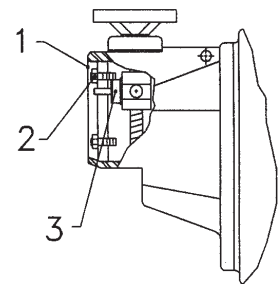

For Electric Remote Control units, see electrical connections and speed stop setting on pages 3 and 4. Please refer also to the motor's operating instructions.

Maintenance and Lubrication

VARIGEAR® variable speed units are largely maintenance free. The VARIGEAR® drive case itself does not require oil since it is a belt type drive. However, for units which are flange mounted to a gear reducer, there is an oil plug located in the VARIGEAR® flange. Depending on the drive mounting position, this plug may be used as a breather or oil level plug for the reducer. This plug does not connect to the VARIGEAR® housing. Refer to the Operating Instructions for Gear Reducers for proper gearcase oil level.

If the V-belt needs to be changed, the unit size and the speed range must be given. An indication that the belt needs to be changed is when the entire adjustment range can no longer be obtained (due to belt elongation and flank abrasion). The belt changing procedure for each size VARIGEAR® follows:

Belt change for sizes VU 01 ... 51

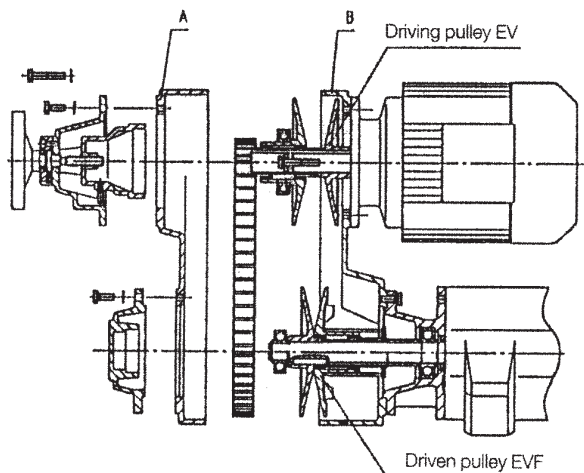

1. Run the drive to its maximum speed and switch off. (Ensure that the unit cannot be inadvertently switched on again.)
2. Dismantle the speed control unit from the beltcase.
3. Dismantle the bearing cover and vent plates.
4. Remove attaching bolts and separate the beltcase half A from B.
5. Insert and press wooden wedge into the driven pulley (opened by the procedure item 1).
6. Draw the belt over the cones of the driven pulley and then remove.
7. Install the new belt in the reverse order: first insert the belt into the driving pulley and then draw over the cones of the driven pulley.
8. Remove the wooden wedge.
9. Carry out the remaining assembly in the reverse order as described above.

Belt change for VU 6

1. Run the drive to its maximum speed and switch off. (Ensure that the unit cannot inadvertently be switched on again.)
2. Open the driving pulley EV by rotating the hand wheel (6) until it engages with the stop corresponding

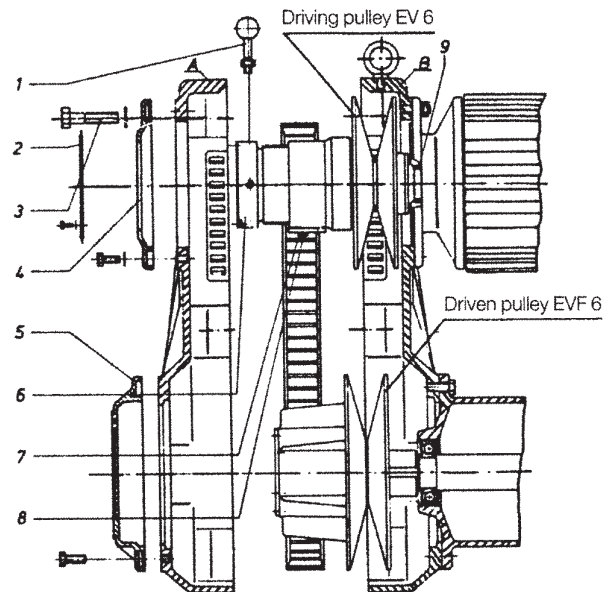

- to minimum operating speed.
3. Remove the end covers (2 & 4) from the beltcase.
4. Remove attaching bolts (1) and separate the belt case half A from B.
5. Insert and press a wooden wedge into the driven pulley EVF (opened by the procedure in item 1).
6. Draw the belt over the cones of the driven pulley and then remove.
7. Install the new belt in the reverse order: first insert the belt into the driving pulley and then draw over the cones of the driven pulley.
8. Remove the wooden wedge.
9. Install the new belt in the reverse order: first insert the belt into the driving pulley and then draw over the cones of the driven pulley.
10. Standard handwheel adjusting stiffness may be changed by loosening locknut (7) and turning the stud (8) in or out. Re-tighten locknut (7).

Belt change for sizes VZ 01 ... 41

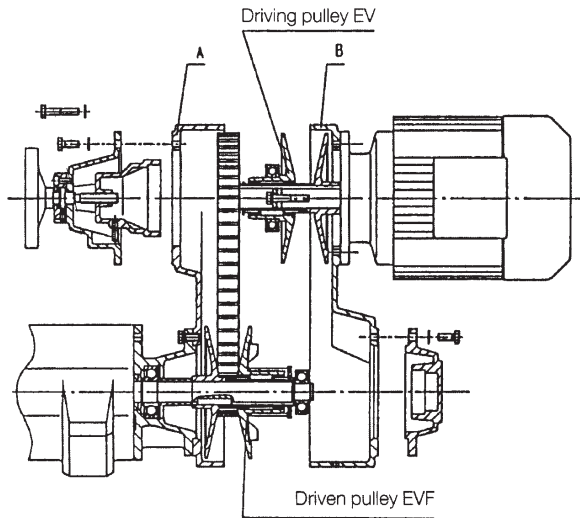

1. Run the drive to its maximum speed and switch off. (Ensure that the unit cannot inadvertently be switched on again.)
2. Dismantle the speed control unit from the beltcase.
3. Dismantle the bearing cover and vent plates from the beltcase.
4. Support the weight of the motor.
5. Remove attaching bolts (1) and separate the beltcase half A from B.
6. Lower the beltcase B with respect to A a little.
7. Insert and press a wooden wedge into the driven pulley EVF (opened by the procedure in item 1).
8. Draw the belt over the cones of the driven pulley and then remove.
9. Fit the new belt in the reverse order: first insert the belt into the driven pulley and then draw over the cones of the driving pulley.
10. Remove wooden wedge.
11. Carry out the remaining assembly in the reverse order as described above.

- Grease packed bearings should be cleaned and regreased every 10,000 hours with Mobilux EP2 or equivalent. Care must be taken that only 1/3 of the free volume of the bearing space is filled with grease in order to avoid overheating of the bearing.
- Periodically the threaded speed adjusting spindle should be relubricated with a suitable grease such as Never-Seez®.
- Check coupling alignment, chain or belt tension, and mounting bolt torque periodically.
- To ensure adequate cooling, deposits of dirt and

dust on the surfaces of the units must be removed at frequent intervals. Particular attention should be paid to the motor by removing all deposits from between the motor cooling fins and also from the air intake on the fan guard.

Setting of the Speed Range Limits - Option EF

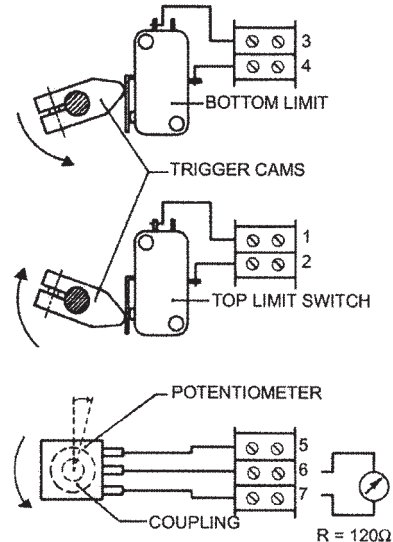
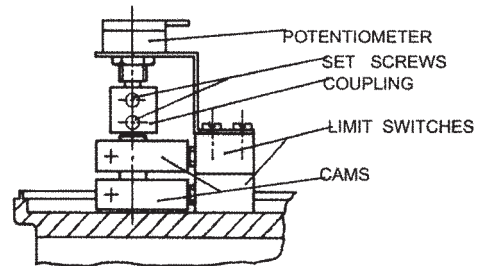

The Limit Switches and Potentiometers are factory preset for maximum speed range. To modify the speed range, the limit switches may be field adjusted. The switches and potentiometers are located under the cover of the speed control motor.

Limit Switch Adjusting Instructions:

1. Remove cover.
2. Run the Speed Control Motor to obtain the maximum drive output speed.
3. Rotate the CAM for the Top Limit Switch clockwise until it trips the Limit switch. Tighten the locking screw.
4. Run the Speed Control Motor to obtain the minimum drive output speed.
5. Rotate the CAM for the Bottom Limit Switch counter-clockwise until it trips the Limit Switch. Tighten the locking screw.

Potentiometer Adjusting Instructions (used for closed loop system control):

1. Turn the potentiometer counter-clockwise until it runs against the stop (Variable Speed Unit must be at minimum speed). Turn the potentiometer approximately 15° clockwise. Between terminals 6 & 7 there must be a resistance of 120 ohms.
2. Tighten the coupling set screws.

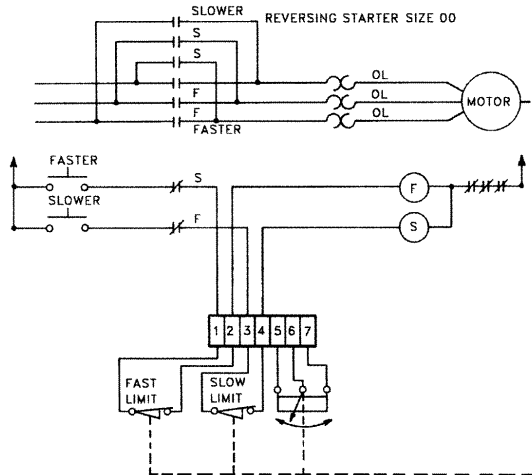

NOTE:
Pushbutton and motor starter are not supplied by SEW-Eurodrive.
See Previous Page for adjusting the limit switches.

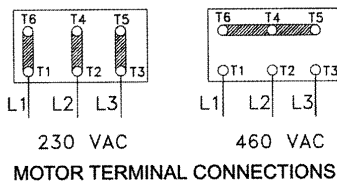

Motor Current for all VARIGEAR®
Sizes @ 230V/460V: 0.55A/0.32A

The speed control motor is rated for 15% ED (cyclic duration factor) and a maximum starting frequency of 20 per hour.

WIRING DIAGRAM FOR SINGLE PHASE REMOTE SPEED CONTROL MOTORS - OPTION EF

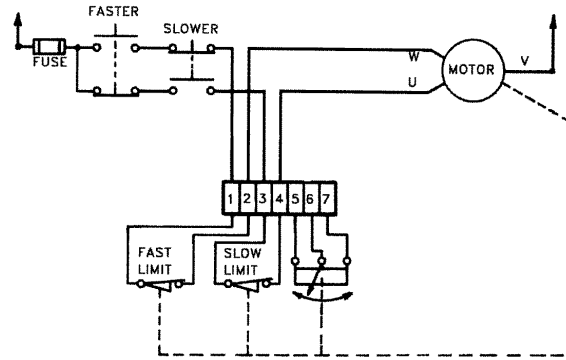

NOTE:
Fuse and pushbuttons are not supplied by SEW-Eurodrive.
See Previous Page for adjusting the limit switches.

CAPACITOR 30µF

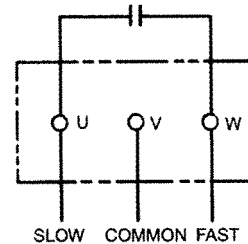

MOTOR TERMINAL CONNECTION

Motor Current for all VARIGEAR®
Sizes @ 115V: 2.1 Amps

The speed control motor is rated for 15% ED (cyclic duration factor) and a maximum starting frequency of 20 per hour.



SOUTHEAST MANUFACTURING & ASSEMBLY CENTER
1295 Spartanburg Highway/Lyman SC 29365
(864) 439-7537 Fax: (864) 439-7830

SOUTHWEST ASSEMBLY CENTER
3950 Platinum Way/Dallas TX 75237
(214) 330-4824 Fax: (214) 330-4724

MIDWEST ASSEMBLY CENTER
2001 West Main Street/Troy OH 45373
(937) 335-0036 Fax: (937) 222-4104

EAST COAST ASSEMBLY CENTER
200 High Hill Road/Bridgeport NJ 08014
(609) 467-2277 Fax: (609) 845-3179

WEST COAST ASSEMBLY CENTER
30599 San Antonio Road/Hayward CA 94544
(510) 487-3560 Fax: (510) 487-6381