

CONTENTS:

1.0 General

- 1.1 Introduction
- 1.2 Function

2.0 Technical Data

- 2.1 Temperature Sensor
- 2.2 TSE Control Device for Installation in Control Panel

3.0 Electrical Connection of the TSE

- 3.1 Installation Instructions
- 3.2 Connection Diagram of TSE Control Device
- 3.3 Relay Function

4.0 Procedures prior to Commissioning

- 4.1 Check Position of the Temperature Measuring Point at the Pump
- 4.2 Function Check
- 4.3 Approximate Adjustment of Trip Temperature

5.0 Commissioning and Operation

- 5.1 Fine Adjustment of Trip Temperature
- 5.2 Resetting of the Control Device after Dry-Running
- 5.3 Changeover of Display from °C to °F

6.0 Replacement of Stator

- 6.1 Order of Replacement Stator
- 6.2 Dismantling and Re-Assembly of Connection Head and Temperature Sensor

7.0 Malfunction

- 7.1 General
- 7.2 Function Check of Sensor Circuit
- 7.3 Function Check of TSE Control Device

8.0 Enclosures

- 8.1 Drawing 702-007__ for sizes 006-12 and 025-6L
- 8.2 Drawing 702-006__ for sizes 025-12 up to 500-6LA
- 8.3 Additional Information ZU.TSE.02 for TSE Motor Control
- 8.4 Additional Information ZU.TSE.03 for TSE in Explosion Proof Construction

1.0 General

1.1 Introduction

Progressive cavity pumps should generally be protected against dry-running. Due to the increased friction between the main conveying elements ie. rotor and stator, which occurs in the event of dry-running the pump, the temperature at the internal surface of the stator can quickly rise depending on the pump speed.

When exceeding the max. permissible operating temperature the internal surface of the stator will burn and cease operation. If this occurs the stator needs to be replaced. The possible malfunction of an progressive cavity pump can be easily avoided by using the patented dry-running protection device TSE.

1.2 Function

The general operating principle of the dry-running protection device TSE is to continuously monitor the temperature in the stator and to trip the pump when reaching a limit temperature. The temperature in the pump stator is compared with the pre-set trip temperature via a NTC temperature sensor, which is fitted in the stator of the pump as well as the TSE control device, which is positioned in the control panel. In case of dry-running of the pump and a temperature increase in the stator up to the pre-set switch-off value, two relays will switch.

The drive motor of the pump will be switched-off via the potential-free changeover contacts and a fault message will be released. After rectification of the cause of the dry-running and the cooling down of the stator, the fault message at the TSE device can be acknowledged and the pump can be switched on again.

By acknowledging the fault message an automatic re-connection without inspection and correction of the cause of the dry-running is avoided.

2.0 Technical Data

2.1 Temperature Sensor

The NTC thermister is installed in a stainless steel protection sleeve in the stator of the pump.
Permissible Temperature Range: 0-150 °C
Standard Resistance: 10 kOhm at 25 °C

Temp. °C	Resistance Ohm	Temp. °C	Resistance Ohm
0	32.650	70	1.752
10	19.900	80	1.255
20	12.490	90	915
25	10.000	100	678
30	8.057	110	510
40	5.327	120	389
50	3.603	130	301
60	2.488	140	235

2.2 TSE Control Device for Installation in Control Panel

2.2.1 Technical Data

Type:	SGRTSE 230 AC, SGRTSE 115 AC, SGRTSE 24 AC, SGRTSE 24 DC
Temperature Range:	0-150 °C
Input:	NTC temperature sensor 10 kOhm (at 25 °C) with sensor breaking protection at - 25 °C.
Relay Output: changeover	2 potential-free contacts (K1,K2), breaking capacity 500 VA at 110/230 V Ohmic load.
Deliverable	
Operating Voltage:	24V, 115V, 230V AC; 24V DC
Power Consumption:	max. 4VA
Sensor Circuit:	No load voltage max. 2.5 VDC Short circuit current 0.5 mA DC
Display at Device:	Fault/Dry Running Trip temperature Stator temperature
Operation at Device:	Adjustment of trip temperature. Reset of fault message.
Casing Material:	ABS
Fastening:	Mounting on standard rail 35 mm acc. to standards or screw fixings acc. to standards
Kind of Protection:	Casing IP 40 Terminals IP 20
Ambient Temperature:	0-50 °C
Dimension:	45x75x110 mm (WxHxD)
EMV (89/336/EEC)	CE conform acc. to standards

**2.2.2
Dimensions and Wall Mounting**

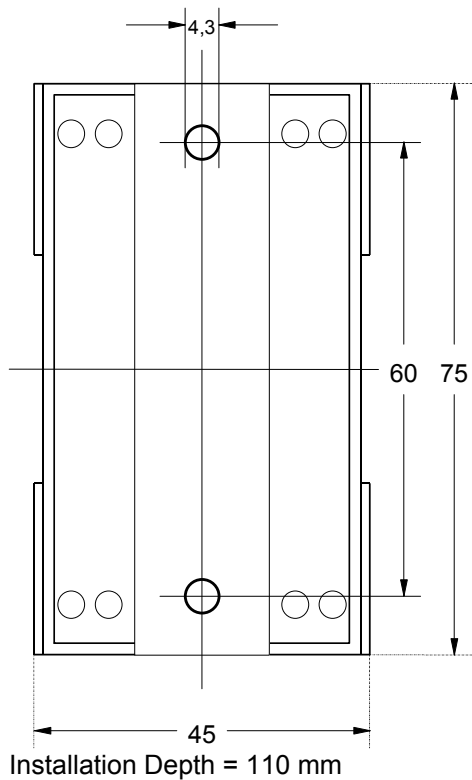

**3.0
Electrical Connection of the TSE**

**3.1
Installation Instructions**

Prior to the connection and the commissioning of the device it has to be ensured that the supply voltage corresponds to the nominal voltage shown on the name plate. Nominal voltage fluctuations are permissible in the range of +/- 10 % of the device's nominal voltage.

The electrical connections have to be carried out in accordance with the wiring diagram and the regulation of the local EVV or the VDE directions.

In case of power fluctuations which lead to a malfunction of the device, adequate procedures have to be taken to avoid its reoccurrence. Alternatively these errors could be filtered out by an external supply filter. The device has to be provided with an internal supply filter.

Sensor leads have to be shielded. The shield has to be earthed at one end.

**3.2
Connection Diagram of TSE Control Device**

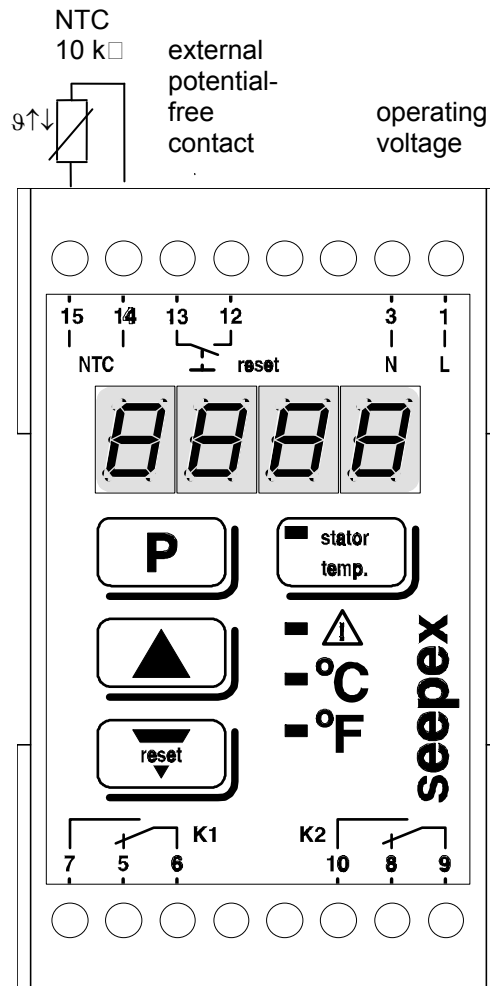

Should the TSE control device be reset after a dry-running from the control panel door or another remote position, a button ("make contact") at the terminals 12 +13 can be used.

**3.3.
Relay Function**

Actual temperature < trip temperature
(trouble free operation)
Contacts 6 to 7 and 9 to 10 closed
Contacts 6 to 5 and 9 to 8 open

Actual temperature > trip temperature
(Malfunction/Dry Running)
Contacts 6 to 5 and 9 to 8 closed
Contacts 6 to 7 and 9 to 10 open

Relays K1 and K2 are switched parallel to each other and operate simultaneously. K1 is integrated in the motor contactor control serving as a switch-off provision. K 2 is optional as stand by for additional connection to a fault indicator or as a reserve to the process control computer.

4.0 Procedures prior to Commissioning

4.1 Check Position of the Temperature Measuring Point at the Pump

Considering the rotating direction and thus the conveying direction of the pump, the temperature sensor is fitted in our factory as per the following figures.

When changing direction of the pump and when replacing the stator the specified installation position of the temperature measuring point has to be checked. The temperature sensor must always be installed at the product entry side of the stator as the quickest temperature increase in case of dry-running will arise at this point.

4.1.1 Pump "counter clockwise rotation" - standard construction

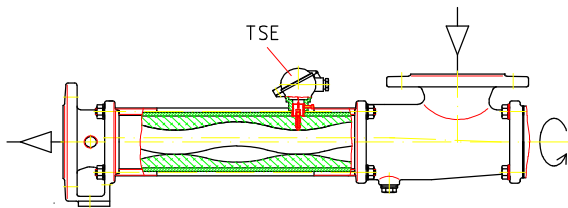

4.1.2 Pump "clockwise rotation" special construction

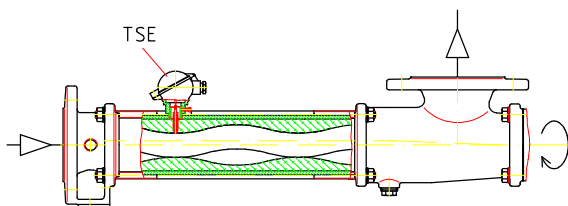

4.2 Function Check

After the electrical connection of the TSE and prior to the initial operation of the pump the following function check has to be carried out.

Switch-on control voltage at terminals 1 and 3 (Digital display at the TSE control device illuminates).

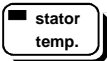
 Press and hold button "stator temp" and read the temperature value.

If the shown temperature correspond to the ambient temperature in the pump the TSE is functioning correctly. In case of deviation proceed as per paragraph 7 - Malfunctioning.



4.3 Approximate Adjustment of Trip Temperature

The TSE control device is pre-set to a trip temperature of 50 °C prior to leaving our factory. In order to achieve the shortest trip time after a dry-run and thus the max. protection of the pump stator, the trip temperature at the TSE control device has to be set as low as possible.

For the initial commissioning the temperature value pre-set in our factory should be maintained. Should the product have higher temperatures the value has to be adjusted to 20 to 30 °C above the temperature of the conveying product.

Switch on control voltage. After self-check of the control device the actual pre-set temperature will show at the display.



Press and release button. Adjusting Mode is activated. The displays shows alternately "set" and the last set trip temperature.



Increasing the trip temperature - press button and release. The adjusted temperature increases by + 1°C. Press button and hold approx. 3 seconds in + 10 °C steps.



Decreasing of trip temperature - press button and release. The adjusted temperature decreases by - 1° C. Press button and hold approx. 3 sec. in - 10° C steps.



Press and release button. Return the unit to the operating mode. The adjusted trip temperature is transferred to a continuous memory and shown on the display.

Note: During the adjusting mode, if a button is not pressed within 10 seconds the controller automatically returns to the operating mode and disregards any previous adjustment.

Following the above approximate instruction, the seepex pump can operate for a limited period of time (approx. 1 hour). Then a correction of the adjustment according to paragraph 5 - Fine Adjustment - has to be carried out.



5.0 Commissioning and Operation

5.1 Fine Adjustment of the Trip Temperature

Following the instruction for approximate adjustment in paragraph 4.3 the seepex pump has to operate for at least 30 to 60 minutes to allow the operating temperature in the stator become stable.

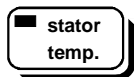

While the pump is in operation the temperature of the pump is shown on the display of the TSE controller by continuously pressing the button.

The final trip temperature has now to be set 10 °C higher than the indicated operating temperature according to the instructions in paragraph 4.3.

Attention

For all adjustments the max. product temperature occurring during operation has always to be considered. In case of a product temperature higher than 40 °C, it always has to be checked if this is mentioned in the data sheet of the pump and has therefore been considered in the rotor/stator design. If the temperature shown on the data sheet does not correspond to the actual temperature, please contact seepex.

5.2 Resetting of the Control Device after Dry-Running

In the event of dry-running of the pump and temperature increase in the stator above the pre-set limit value, the installed relays trip and maintain locked in this position. After the pump has cooled down the remaining fault message (red LED) has to be acknowledged using one of the following procedures, so that the relay will be reset.

5.2.1



Press at the TSE control device for at least 1 sec.

5.2.2

Switch-off operating voltage at TSE control device (terminals 1-3).

5.2.3

With external contact (reset button, closed for at least 1 sec.)

5.3 Changeover of the Display from °C to °F.



Press and hold button for 10 secs. until display changes over.

The selected temperature units are shown via an LED next to the Symbol °C or °F.

6.0 Replacement of Stator

6.1 Order of Replacement Stator

When ordering a replacement stator for a seepex pump, please quote:

Stator drilled for TSE fitted with sensor sleeve in 1.4571.

If the pump is used to convey highly corrosive products where 1.4571 material is not resistant, a sensor sleeve made of 2.4610 (Hastelloy C4) has to be ordered.



Attention

The sensor sleeve is fitted in our factory. It is pre-set for operation and may not be adjusted.

6.2 Dismantling/Re-Assembly of the Connection Head and Temperature Sensor.

The following drawings apply:

- For TSE in elastic stators:
Drawing No. 702-007__ for pump sizes 006-12 and 025-6L.

Drawing No. 702-006__ for pump sizes 025-12 to 500-6LA.

- For TSE in firm stators:
Drawing No. 702-008 __

6.2.1 Dismantling

Lift the cover of the connection head and disconnect wires of the temperature sensor. After having loosened the side screw slide the connection head off the threaded sleeve. Remove threaded sleeve from the stator and remove clamping ring, rubber ring and temperature sensor from sensor sleeve. The temperature sensor cannot be re-used and can thus be disposed off with the damaged stator.

**6.2.2
Re-Assembly**

The items mentioned in paragraph 6.2.1 have to be re-installed into the new stator. It is vital to consider the temperature measuring point when installing the stator (refer to paragraph 4.1).

Do not further adjust or change the sensor sleeve setting as this has already been done in our factory.

Remove protective pipe (protective transport packaging).

Push the thermistor sensor with clamping screws and rubber ring to the bottom of the sensor sleeve and adjust.

Screw the threaded sleeve with 2 O-Rings in the tapped hole at the stator.

When installing the connection head, the connection wires of the thermistor sensor must be threaded through the hole in the junction box. After fastening the connection head on the threaded stator bar, reconnect wires and put the cover back onto the connection head.

**7.0
Malfunction**

**7.1
General**

Fault messages and switch-off of the pump without actual dry-running or overload might be caused by a defect in the temperature sensor wire, the TSE control device or other electrical switch devices.



The following reasons might have caused this error alarm at the TSE control device:

- break of sensor or line
- short circuit of sensor or line
- measuring range (-25 ...150°C) is exceeded or remained under

The following procedure is recommended to check the TSE control device and the sensor circuit including temperature sensor:

**7.2
Function Check of Sensor Circuit**

Disconnect the temperature sensor wire at the TSE control device terminals 14 and 15 and connect a resistance measuring device (Multimeter or Ohmmeter). The measured electrical resistance must conform with the value in the table shown in paragraph 2.1 in accordance with the pump temperature. In case of deviations of the resistance value of more than 10% of the set value, measure the resistance at the connection head of the TSE at the pump. To do this the wire to the control device at the connection head of the pump needs to be removed. If the same deviations occur when measuring the resistance at the temperature sensor directly at the pump, the temperature sensor is damaged and needs to be replaced (refer to paragraph 6.2 and 6.3).

Should the resistance check at the temperature sensor show correct values, then damage to the connection cable or the connection terminal is the cause of malfunction.

**7.3
Function Check of TSE Control Device**

If a trouble-free sensor circuit has been determined during the testing according to paragraph 7.2, damage to the TSE control device is most likely. In order to carry out the check, remove the sensor wires at terminals 14 and 15 and connect a commercial deposited carbon or metal film resistor as per the following list.:

Resistance (Ohm)	Switching Temp. °C
10.000	25
5.600	39
2.200	63
1.000	87
560	107
220	143

Switch-on control voltage at terminal 1+3 (Digital Display at the TSE device illuminates)

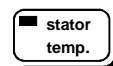

Press and hold button "stator temp." and read the temperature value.

The shown value must correspond to the switch temperature, which applies to the resistance used. Should the shown value deviate by more than 5-10 °C or should the value be absent at all, the TSE control device must be sent to seepex for repair.