

**seepex.com**  
all things flow

Here is your conveying solution:  
Product group W.



# W – Wobble pumps

Pumps of product group W can be used in almost all industries. They are designed to handle liquids of all viscosities and even products with high solids contents. They are cost effective and versatile.

---

## Joint connection

consisting of just 5 components. Power transmission through wear resistant, hardened and replaceable joint parts, easily repaired.

## Rotor

wear resistant and corrosionproof materials, with additional surface treatment.

## Stator

flexible stator, fixed on one side.

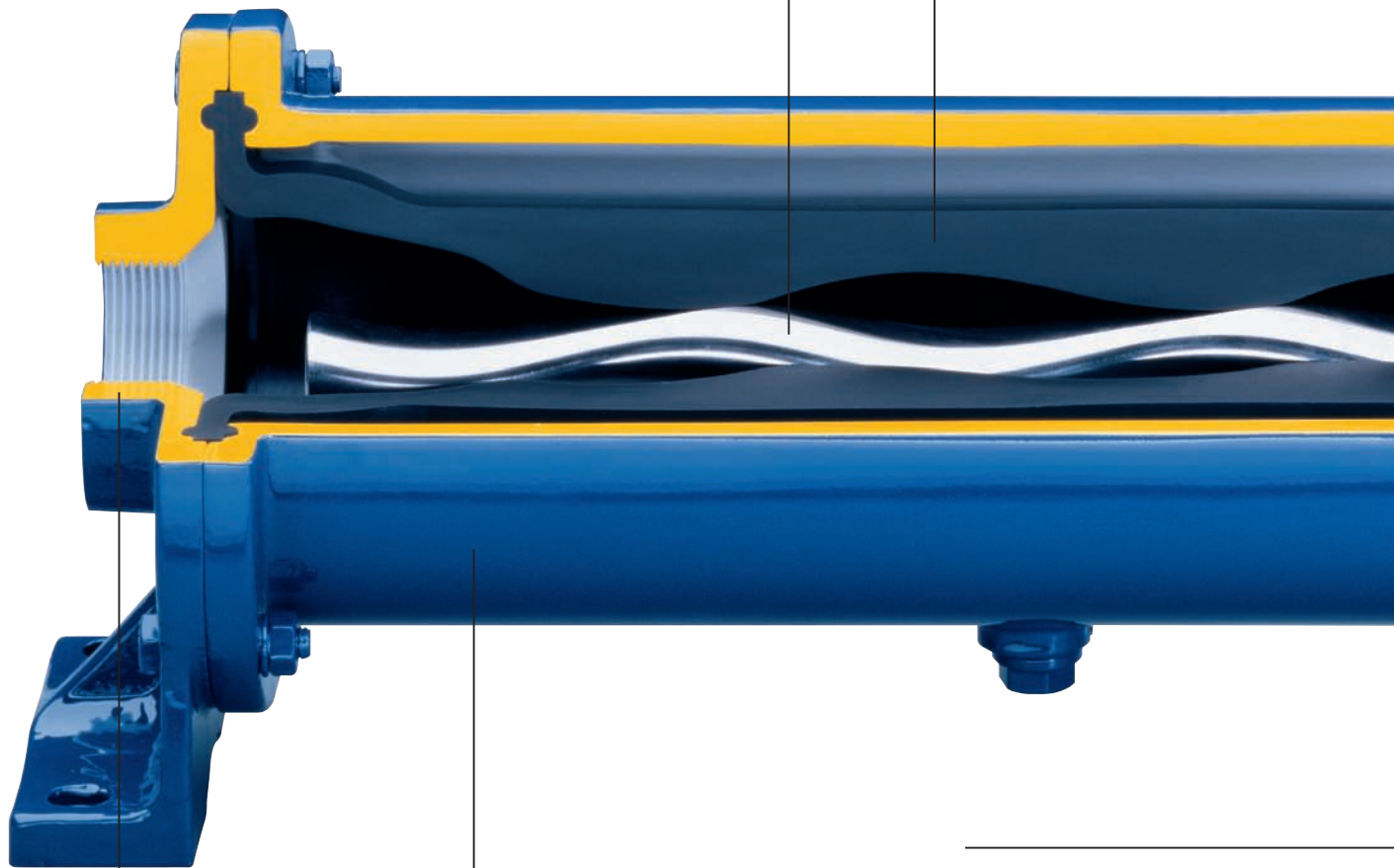

## Suction branch

flange connection according to DIN EN ISO 228-1 or NPT.

## Pressure casing

with drain plug and connections for pressure/vacuum gauge. Flange connections according to DIN EN ISO 228-1 or NPT, can be rotated in 90° increments.

---

## Universal joint sleeve with holding bands

protects the grease-filled joints from penetration of the pumped product, even in case of maximum vacuum or pressure loading.

**Shaft sealing**  
single-acting mechanical seal,  
located inside the pumped product.

**Shaft sealing retainer**  
for retaining the mechanical seal  
and for centring of the drive.

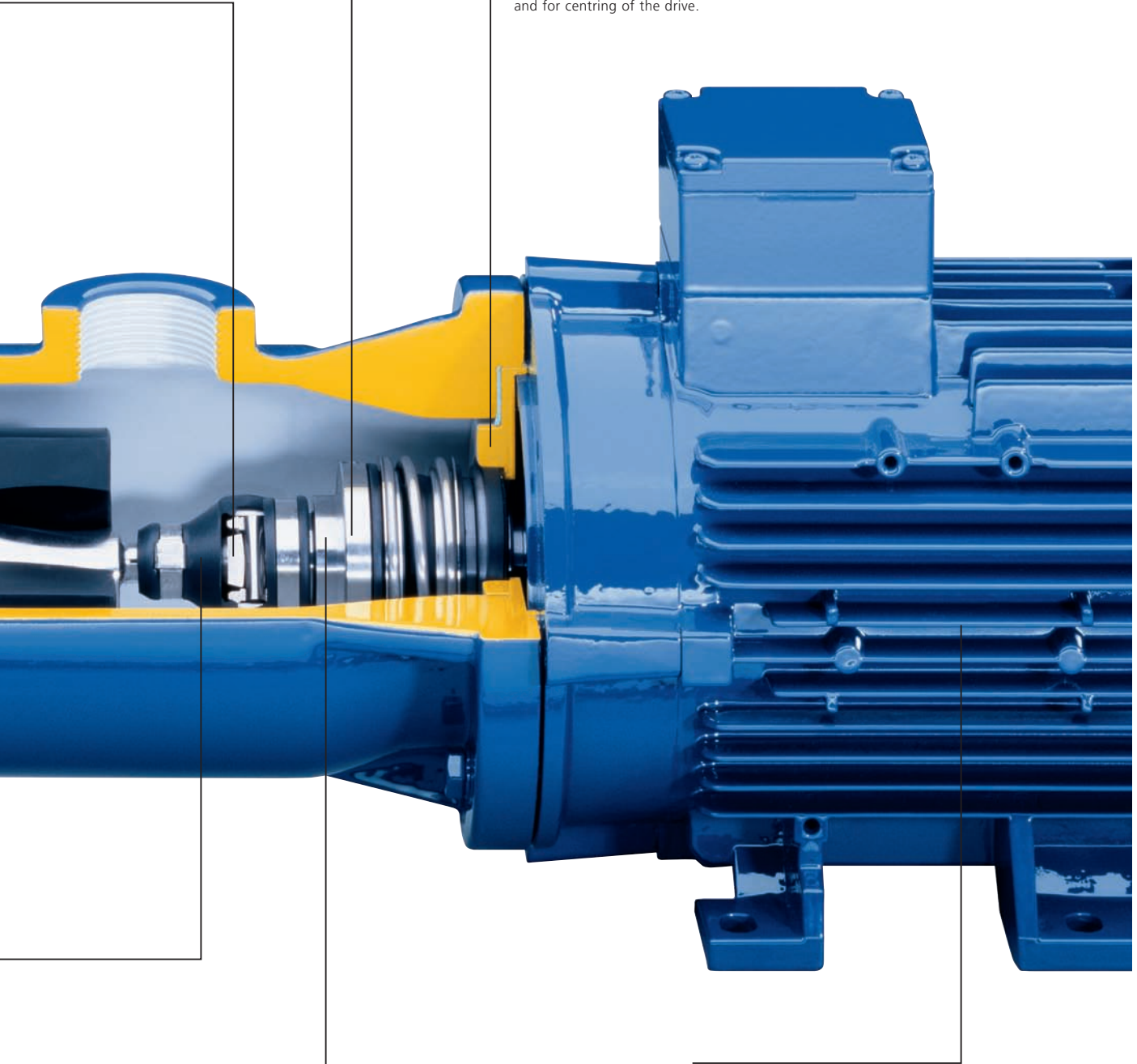

**Plug-in shaft**  
connects the drive shaft to the  
joint.

**Drive**  
electric motor, directly flanged to the pump  
without additional couplings or guards, upon  
request geared motor or variable speed drive  
available.

# Why wobble pumps?

Because they are used in applications such as agriculture, ceramics, chemical and biochemical industry, construction, dyeing and varnishing, electroplating, environment technology, fish industry, food and beverage industry, mining, non-metallic minerals, oil production and offshore technology, petrochemicals, pharmaceutical and cosmetics industry, pulp and paper industry, shipbuilding, sugar industry, supply and waste disposal industry, textile industry, vehicle construction and equipment and wood processing industry.

## Features

- Service-friendly and economical due to simple pump construction
  - Rapid exchange of conveying elements due to rotating unit with only one joint
  - Space-saving due to short, compact design with directly flanged drive (block design)
- > Conveying capacity: up to 10 m<sup>3</sup>/h (44 GPM),  
Pressure: up to 4 bar (60 psi)

## Benefits

- Improved geometries for improved efficiency
- Flat performance curves for predictable performance
- Thick stator cross sections reduce "slip" and improve longevity
- Unique stator design eliminates stress "risers"
- Reliable in thousands of "grinder" pump applications
- The seepex universal joint system, proven for 35 years
- DIN 24960 seals for easy and inexpensive maintenance
- Silicon carbide seal faces for long life
- Close coupled designs with 4 and 6-pole motors
- Energy efficient motors suitable for VFD operation
- Pumps and motors are stocked for immediate shipment
- Available in cast iron and stainless steel
- Available in direct drive and several variable speed designs

## Overview of ranges

Pumps of the BW range are very easy to handle and economical. In contrast to conventional progressive cavity pumps, they have only one joint, which saves costs and reduces downtime when replacing spare parts. The wobble-stator pump is also space saving because the lantern has been dispensed with – the drive is flanged onto the pump directly.

Range BW

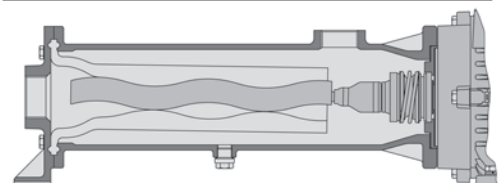

# Characteristic Curves

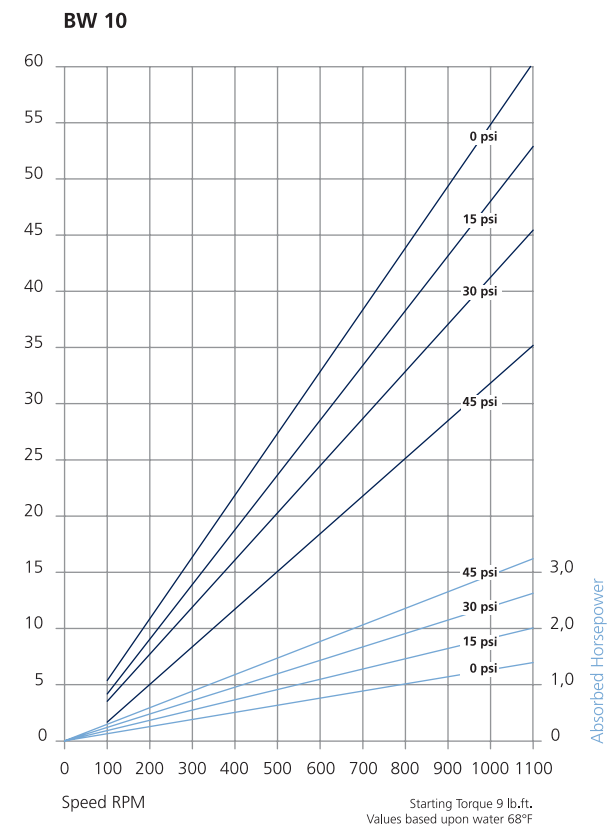
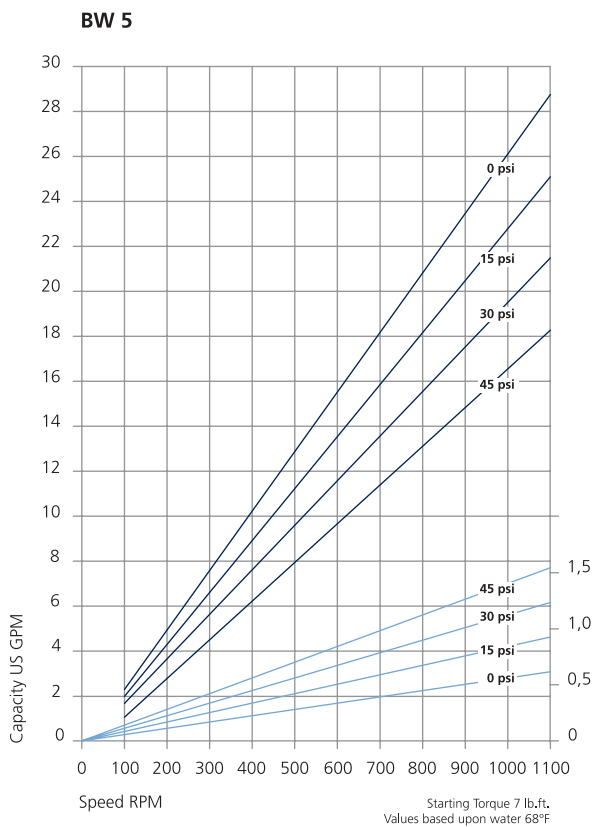
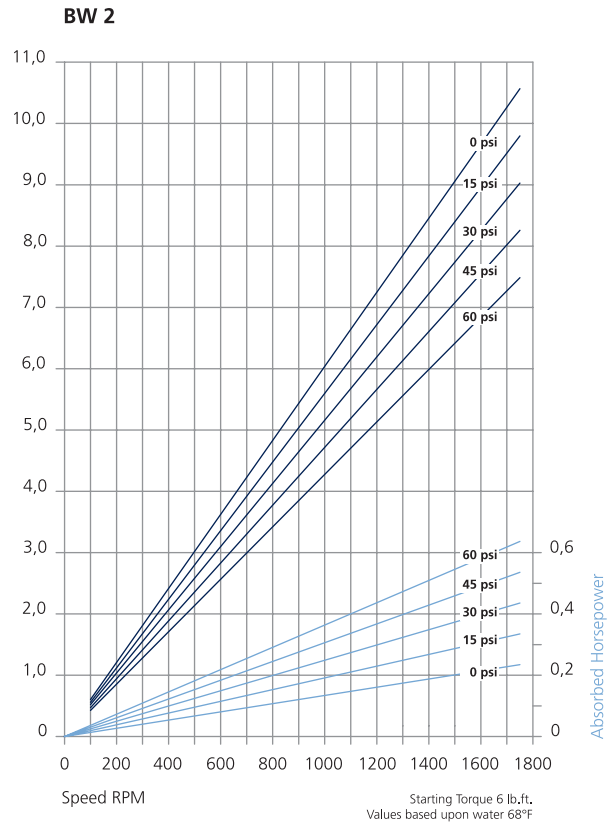
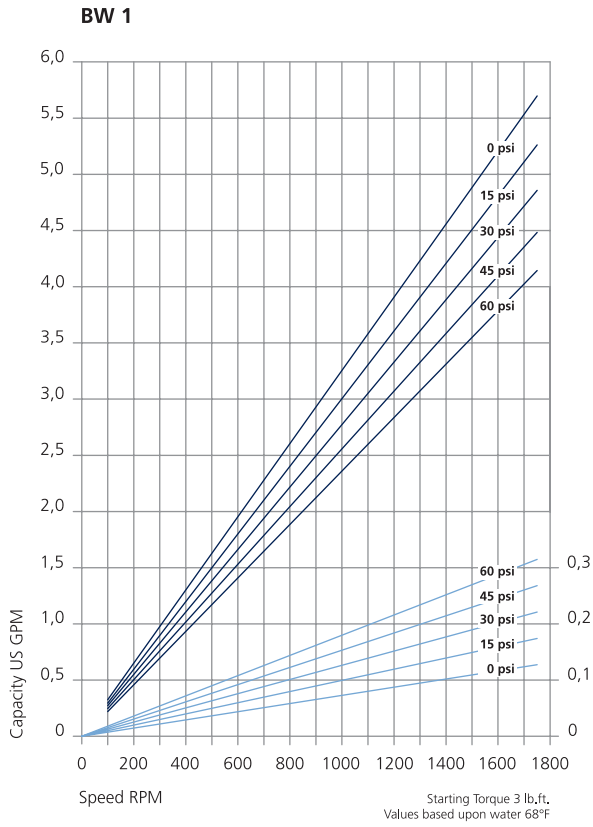

# Dimensions and drives

Pump Configuration – All dimensions in inches	Overall length	Overall width	Overall height			
	A	B	F	C	D	E
<b>BW 1+2</b> with seepex DC motor and controller	23 9/16"	6 7/8"	6 31/32"	7 7/32"	3 29/32"	2 25/32"
<b>BW 1+2</b> with AC motor and controller	22 15/16"	7 15/32"	11 7/32"	7 7/32"	3 27/32"	3 1/2"
<b>BW 1+2</b> with mechanical VS drive SPFD05/M71/B3B5 (1-1.000 rpm) <sup>1</sup>	24 3/16"	6 5/8"	8 3/8"	7 7/32"	3 13/16"	3 5/32"
<b>BW 1+2</b> with Baldor 1 x 120 VAC 60 Hz 1.5 HP, 1750 rpm direct coupled motor	22 1/2"	9 7/16"	9 1/32"	7 7/32"	5 3/4"	3 1/2"
<b>BW 1+2</b> with Baldor 3 x 230/460 VAC 60 Hz 1.5 HP, 1750 rpm direct coupled motor	22 1/2"	9 3/8"	7 3/32"	7 7/32"	5 3/4"	3 1/2"
<b>BW 1+2</b> with Baldor 3 x 230/460 VAC 60 Hz 1 HP, 1150 rpm direct coupled motor	22 1/2"	9 1/8"	9 1/32"	7 7/32"	5 3/4"	3 1/2"
<b>BW 5</b> with Baldor 3 x 230/460 VAC 60 Hz 3 HP, 1750 rpm direct coupled motor	45 3/8"	9 3/4"	10"	14 1/32"	4 7/8"	4 1/2"
<b>BW 5</b> with Baldor 3 x 230/460 VAC 60 Hz 2 HP, 1150 rpm direct coupled motor	19 1/4"	11 1/4"	8 5/16"	14 1/32"	6 7/8"	4 13/32"
<b>BW 10</b> with Baldor 3 x 230/460 VAC 60 Hz 5 HP, 1150 rpm direct coupled motor	44 5/8"	13 5/8"	12 9/32"	18 5/16"	8 1/2"	5 3/16"

Pump Configuration – All dimensions in mm	Overall length	Overall width	Overall height			
	A	B	F	C	D	E
<b>BW 1+2</b> with seepex DC motor and controller	598	175	177	183	99	71
<b>BW 1+2</b> with AC motor and controller	582	190	285	183	98	88,9
<b>BW 1+2</b> with mechanical VS drive SPFD05/M71/B3B5 (1-1.000 rpm) <sup>1</sup>	615	168	213	183	97	80
<b>BW 1+2</b> with Baldor 1 x 120 VAC 60 Hz 1.5 HP, 1750 rpm direct coupled motor	571	240	229	183	146	88,9
<b>BW 1+2</b> with Baldor 3 x 230/460 VAC 60 Hz 1.5 HP, 1750 rpm direct coupled motor	571	238	180	183	146	88,9
<b>BW 1+2</b> with Baldor 3 x 230/460 VAC 60 Hz 1 HP, 1150 rpm direct coupled motor	572	232	229	183	146	88,9
<b>BW 5</b> with Baldor 3 x 230/460 VAC 60 Hz 3 HP, 1750 rpm direct coupled motor	1152	248	254	356	124	114,3
<b>BW 5</b> with Baldor 3 x 230/460 VAC 60 Hz 2 HP, 1150 rpm direct coupled motor	489	286	211	356	175	112
<b>BW 10</b> with Baldor 3 x 230/460 VAC 60 Hz 5 HP, 1150 rpm direct coupled motor	1133	346	312	465	216	132

<sup>1</sup> handwheel mounts on either side

seepex stocks the most common drives. Shown are several close-coupled, VFD-capable motors, a mechanical variable speed drive and a single-phase, fixed speed close-coupled motor. All are available for quick shipment. Special designs are available.



	Pressure connection	Suction connection	Weight
H	DN1	DN2	approx. in lbs
2 3/8"	1" NPT	1" NPT	55
2 3/8"	1" NPT	1" NPT	86
2 3/8"	1" NPT	1" NPT	49
2 3/8"	1" NPT	1" NPT	49
2 3/8"	1" NPT	1" NPT	49
2 3/8"	1" NPT	1" NPT	49
2 15/16"	1 1/4" NPT	1 1/2" NPT	168
2 15/16"	1 1/4" NPT	1 1/2" NPT	143
3 3/4"	2" NPT	2" NPT	213

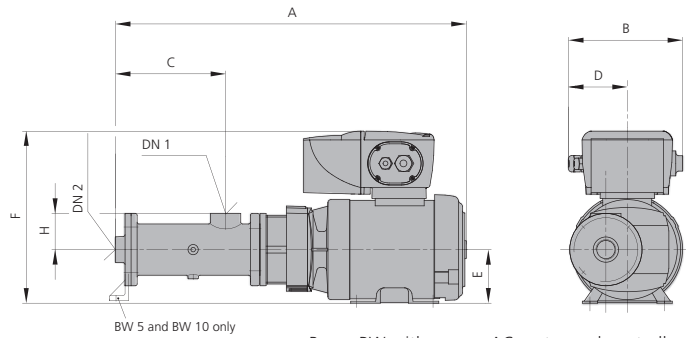

Pump BW with seepex AC motor and controller

	Pressure connection	Suction connection	Weight
H	DN1	DN2	approx. in kg
60	1" NPT	1" NPT	25
60	1" NPT	1" NPT	39
60	1" NPT	1" NPT	22
60	1" NPT	1" NPT	22
60	1" NPT	1" NPT	22
60	1" NPT	1" NPT	22
75	1 1/4" NPT	1 1/2" NPT	76
75	1 1/4" NPT	1 1/2" NPT	65
95	2" NPT	2" NPT	97

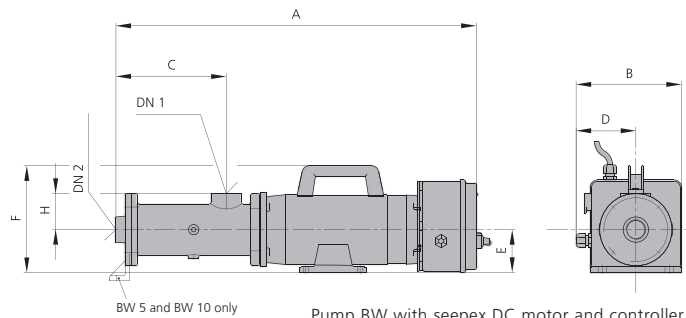

Pump BW with seepex DC motor and controller

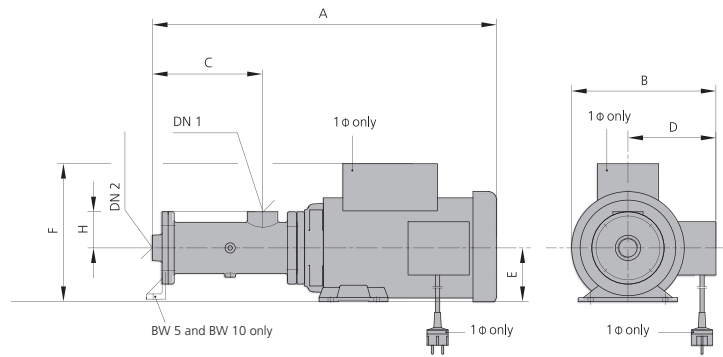

Pump BW with Baldor motor

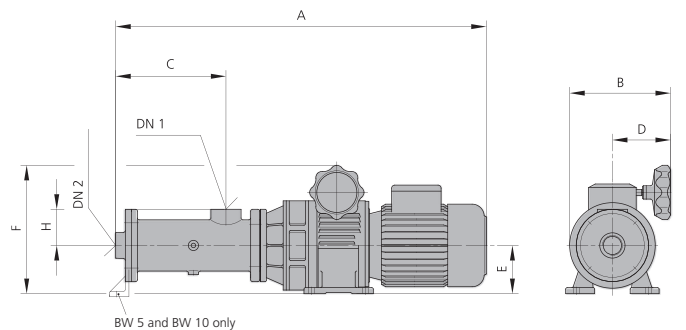

Pump BW with mechanical VS drive

**seepex.com**  
all things flow

And what can we get flowing for you? Your nearest contact:

Or visit [www.seepex.com](http://www.seepex.com)

W 2.08US